

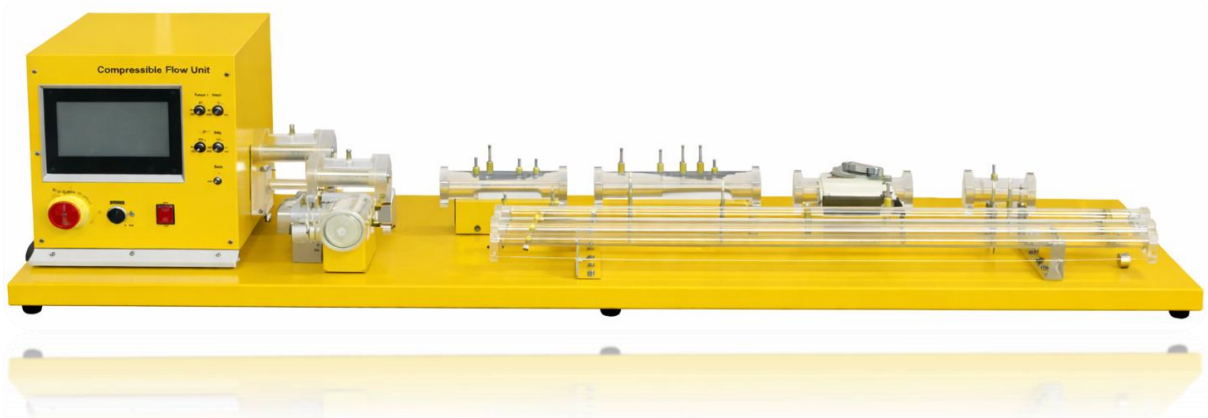

## COMPRESSIBLE FLOW UNIT



### DL HC-CFU

#### INTRODUCTION

In principle, all fluids exhibit compressibility. However, in many practical flow regimes, density variations are sufficiently small to be neglected, leading to the incompressible flow approximation. The incompressible fluid model is an idealization that simplifies analysis by assuming constant density. In contrast, when volumetric changes and density variations are non-negligible, the fluid must be treated as compressible.

The study of compressible flow is fundamental for understanding the influence of pressure, temperature, and velocity on fluid properties, the Compressible Flow Apparatus is a specialized experimental platform designed to investigate the governing parameters and physical behavior of compressible fluids. The system consists of two primary subsystems: A compressed air supply unit integrated with a data acquisition and visualization control module, which provides the operational and measurement infrastructure; and a set of interchangeable experimental modules that enable the analysis of various compressible flow phenomena.

#### MAIN CHARACTERISTICS

- The system incorporates an enhanced electrical safety architecture, featuring robust and reliable grounding to ensure stable operation and compliance with electrical safety standards.
- An integrated electrical and control solution is implemented, enabling real-time acquisition and clear visualization of multi-sensor data via a smart display interface, thereby facilitating efficient data analysis and processing.
- The platform is equipped with a wide range of modular experimental accessories, significantly expanding the scope and diversity of experimental configurations and test scenarios.
- High-strength, corrosion-resistant materials are utilized throughout the structure, resulting in improved mechanical integrity, increased operational safety, and extended service life of the equipment.



- With touch display, fan import fixed module, right angle flow module and measuring nozzle.

## TECHNICAL PARAMETERS

- Power Supply Input: single-phase from the mains, 50/60 Hz.
- Overall Dimensions (L × W × H): 1840 mm × 680 mm × 510 mm.
- Net Weight: 72 kg.
- Ambient temperature:  $-10\text{ }^{\circ}\text{C}$  to  $+40\text{ }^{\circ}\text{C}$ , relative humidity:  $< 85\%$  at  $25\text{ }^{\circ}\text{C}$  (non-condensing).

## INCLUDED ACCESSORIES

- **Touch screen module**  
Input power supply is DC24V, to display parameters of electrical components.
- **Fan import fixed module**  
Inner diameter is 34mm, to connect experimental modules and fixed modules.
- **Right-angle flow module**  
Inner diameter is 34mm, testing module.
- **Measuring nozzle**  
Inner diameter is 34mm, for measuring differential pressure and fixing modules.
- **Suddenly expanded experimental module**  
Inner diameter is 12mm and suddenly changes to 34mm.
- **$\phi 16\text{mm}$  straight tube experimental module**  
Parameters: inner diameter 16mm, length 1m.
- **Name of component 7: Gradually expands the experimental module**  
Inner diameter is 12mm and gradually changes to 34mm.
- **$\phi 24\text{mm}$  straight tube experimental module**  
Inner diameter is 24mm, length is 1m.
- **Experimental module with adjustable valve**  
Parameters: Inner diameter is 34mm.
- **$\phi 34\text{mm}$  straight tube experimental module**  
Inner diameter is 34mm, length is 1m.
- **Variable orifice plate experimental module**  
Inner diameter is 34mm, orifice plate sizes are 12mm, 19mm, 25mm, 32mm.



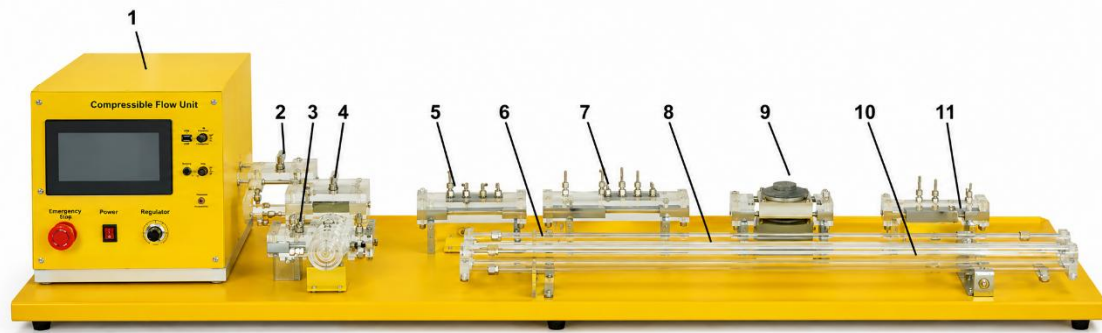

No.	Name	Function
1	Electrical control box	Electrical control and generation of wind pressure required for experiments
2	Fan import fixed module	Used to connect experimental modules and fixed modules
3	Right angle flow module	Experimental modules of the compressible flow device
4	Measuring nozzle	For measuring differential pressure and fixing modules
5	Suddenly expand the experimental module	Experimental module
6	$\phi 16\text{mm}$ straight tube experimental module	Experimental module
7	Gradually expand the experimental module	Experimental module
8	$\phi 24\text{mm}$ straight tube experimental module	Experimental module
9	Experimental module with adjustable valve	Experimental module
10	$\phi 34\text{mm}$ straight tube experimental module	Experimental module
11	Variable orifice experimental module	Experimental module

## TRAINING OBJECTIVES

The system enables the execution of 6 different experimental configurations, designed to analyze pressure losses and flow behavior under various compressible flow conditions, allowing comprehensive study of aerodynamic phenomena.

- Electrical control operation of the compressible flow device.
- Bending flow loss in compressible flow conditions.
- Orifice flow loss under compressible regime.
- Comparison between sudden expansion and gradual expansion flow losses.
- Flow loss in straight pipes with different internal diameters under compressible flow.
- Flow loss characteristics of the regulating valve in compressible flow conditions.