

TRANSISTOR FEEDBACK CIRCUITS

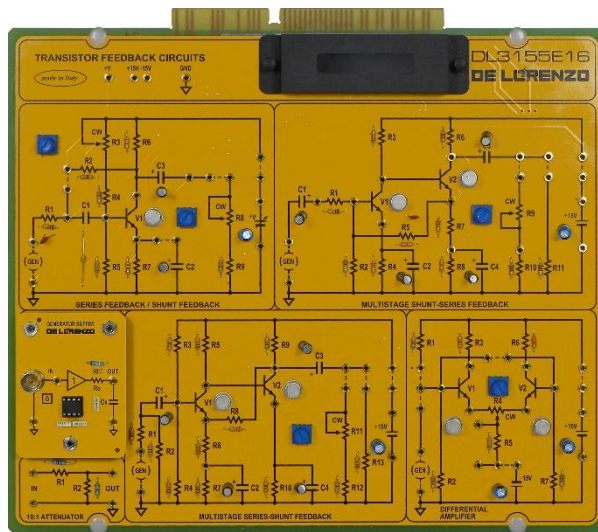

DL 3155E16

The design and construction of electronic circuits to solve practical problems is an essential technique in the fields of electronic engineering and computer engineering.

With this board the students can check the behavior of the feedback circuits with transistors and also the differential amplifier.

THEORETICAL TOPICS

- Typical quantities and basic configurations of a feedback amplifier
- Feedback of a multistage amplifier
- The effects of series feedback on ac gain and on input and output impedance
- The effects of negative series feedback on bandwidth
- The effects of shunt feedback on ac gain and on input and output impedance
- Multistage shunt-series and series-shunt Feedback
- The shunt-series multistage amplifier current gain and output impedance
- Series-shunt multistage amplifier voltage gain and output impedance
- Differential amplifier operation
- Single-ended and differential gain characteristic
- Common mode gain and rejection ratio

CIRCUIT BLOCKS

- Series feedback / shunt feedback
- Multistage shunt-series feedback
- Attenuator
- Multistage series-shunt feedback
- Differential amplifier

Complete with theoretical and practical manual.

Dimensions of the board: 297x260mm

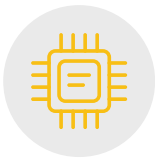

ELECTRONICS



CAI SOFTWARE:

Each board of the TIME system can be supplied complete with a Student Navigator software that allows students to perform their learning activities through a Personal Computer, without the need for any other documentation.

Ordering code: please add SW after the code of the board (i.e. DL 3155E16SW)

Required:

POWER SUPPLY NOT INCLUDED

Base frame with power supply (completed with connecting cables):

- **DL 3155AL3** - Base frame with power supply and interface to pc and virtual instrumentation
- **DL 3155AL2** - Base frame with power supply and interface to pc

Basic power supply (connecting cables not included):

- **DL 2555ALF** - DC power supply $\pm 5 \pm 15$ 0 ± 15 Vdc, 1A
- **TL 3155AL2** - Connecting cables

Choosing this power supply, for the execution of the experiments, it is normally required the use of an oscilloscope and two multimeters.

