

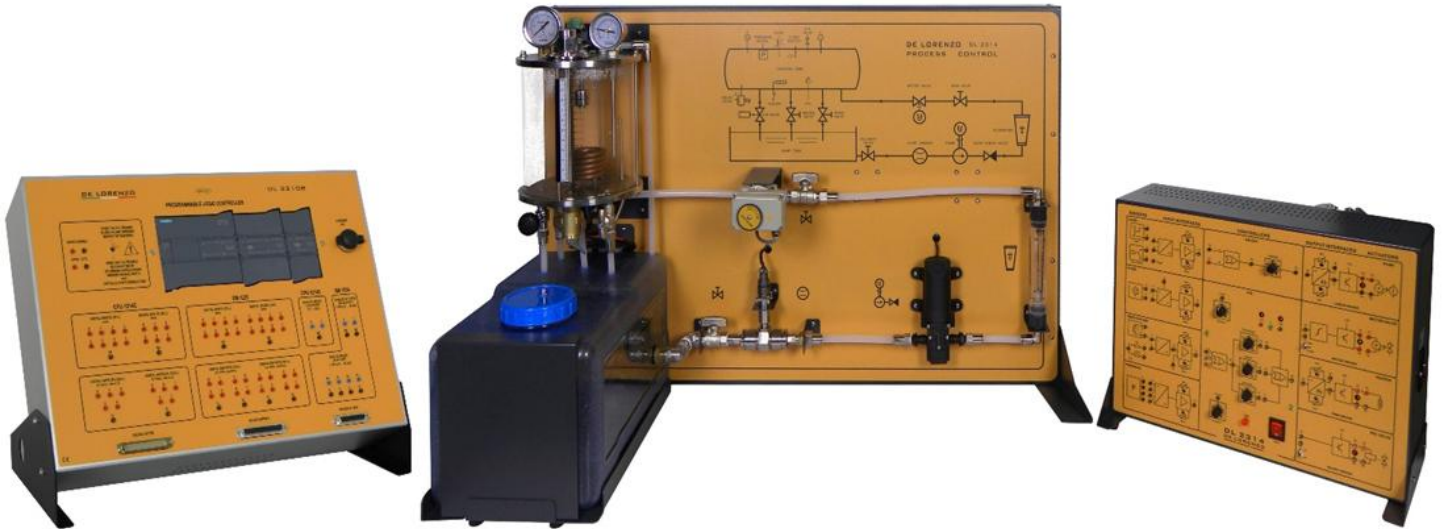

## AUTOMATIC PROCESS CONTROL TRAINER DL 2314PLC



### Product overview

Bench for the study of process control field from basic to advanced levels. It includes valves, pump, tanks, sensors, and drivers. It consists of an experiment module (process panel), a control module with built-in power supply (control panel) and a Programmable Logic Controller (PLC).

With this trainer, the students will be guided step by step into the following experiments;

- How to calibrate a sensor,
- How to obtain the characteristics of a static process and time constant,
- How to control a process by ON-OFF,
- Proportional,
- Proportional-Integral,
- Proportional derivative,
- Proportional-Integral-Derivative and how to perform PLC applications for level,
- Temperature,
- Flow and pressure control systems.

**Ideal for 4 students to work simultaneously.**

Vocational and technical schools.

Applicable to courses in: **Automation, PLC, Sensors and Actuators, PID, Process Control.**

### Highlights

- The trainer allows training flexibility for in all process automation topics and it is composed three different section: **PLC, PROCESS PANEL, CONTROL PANEL**
- With the detailed educational manual, the students will be guided step by step into learning: how to program the PLC, how to calibrate the sensors, how to control a process by ON-OFF system and Proportional-Integral-Derivative system.
- Each experiment, described in detail in the educational manual, is related with real industrial applications.
- The modular trainer offers all modules and components required for basic-to-advanced instruction in processes control and automation.



## LIST OF EXPERIMENTS

- **BASIC COURSE OF PROCESS CONTROL:**
  - Level sensor settings
  - Characteristics of the motor of the pump
  - Characteristics of the pump
  - Characteristics of the static process
  - Time constant of the process
  - ON - OFF control of the level
  - ON - OFF control of the level with "Sol Valve"
  - ON - OFF control of the level with "Float Switch"
  - Closed loop Proportional control of the level
  - Closed loop Proportional-Integral control of the level
  - Closed loop Proportional-Derivative control of the level
  - Closed loop Proportional-Integral-Derivative control of the level
  - Flow sensor
  - Closed loop Proportional control of the flow
  - Closed loop Proportional-Integral control of the flow
  - Closed loop Proportional-Derivative control of the flow
  - Closed loop Proportional-Integral-Derivative control of flow
  - Temperature sensor
  - Measurement of the characteristics of the heating
  - Closed loop Proportional control of the temperature
  - Closed loop Proportional-Integral control of the temperature
  - Closed loop Proportional-Derivative control of the temperature
  - Closed loop Proportional-Integral-Derivative control of the temperature
  - Pressure sensor
  - Pressure sensor as a level sensor
  - ON - OFF control of the level through the pressure sensor
- **BASIC PLC EXPERIMENTS**
  - PLC basic applications: ON - OFF control
  - PLC basic application: PWM control
  - PLC basic applications: Timer control
  - PLC basic applications: Counter control
  - PLC basic control applications: Two functions control
- **ADVANCED PROCESS CONTROL EXPERIMENTS**
  - Level control system. Pumping water station
  - Level control system with time response. Liquid solvent distribution system
  - Temperature control system. Heating water station
  - Flow control system. Liquid distribution system with constant-flow pump
  - Pressure control system with fast time response. Pressure cleaning station
  - PID system with slow time response. Closed loop PID control of level
  - PID system with fast time response. Closed loop PID control of pressure



## TECHNICAL SPECIFICATIONS

The AUTOMATIC PROCESS CONTROL trainer allows the study and performing of experiments in the field of process control. The programmable controller has high performances and easy to use for those who are approaching for the first time the world of PLC.

- **Power supply:** single-phase from mains
- **Programmable Logic Controller**, including:
  - DC power suppl: 24Vdc/2.7A
  - 1 selector for the use of the I/O via sockets or via connectors
  - 1 CPU (Siemens model 1214C of the S7-1200 series) with 14 integrated digital inputs 24Vdc, 10 integrated relay outputs either 24Vdc or relay, and 2 integrated analog inputs 0 to 10V
  - 1 digital expansion module (Siemens model SM 1223) with 16 digital inputs 24Vdc and 16 relay outputs either 24Vdc or relay
  - 1 analog expansion module (Siemens model SM 1234) with 4 analog inputs -10 to +10V or 0 to 20mA and 2 analog outputs -10 to +10V or 0 to 20mA
  - 1 Ethernet LAN port for programming
- **Process Control Trainer/Process panel**, including:
  - Water tank capacity: 20 litres approx.
  - Motor recirculation pump: 6 litres/minute
  - Motor valve: electro modulated valve used for controlling the water flow
  - Motor pump with thermal protection and flow check valve
  - Flow sensor: 8000 pulses/ litre
  - Pipelines (for processing water supply and for water draining out from the process tank)
  - Delivery valve (the main water supply valve)
  - Turbine Flow Meter (flow sensor with volumetric measuring turbine)
  - Visual Flowmeter (indicator for flow rate)
  - Manually valve (for reducing the water flow)
  - Pressurized vessel capacity: 5 litres approx., including:
    - Capacitive level sensor and a Metric scale for measuring the water level (cm or mm)
    - Float switch (to detect the level of water within the pressurized tank)
    - Heating element; Temperature sensor (PT100) and a Thermometer for measuring the temperature inside the process tank (°C or °F)
    - Pressure sensor and a Pressure gauge for measuring the pressure (bar or psi)
    - 4 types of Valves (3 manual and 1 controlled)
    - Safety valve
- **Process Control Trainer/Control panel**, including:
  - Input's interface (Sensors)
    - LEVEL transducer
    - FLOW transducer
    - TEMPERATURE transducer
    - PRESSURE transducer
  - Control's interface (Controllers)
    - ON – OFF
    - ON – OFF with hysteresis
    - PID (P, PI, PD, PID)
  - Output's interface (Actuators)
    - Linear driver for PUMP



- Driver for MOTOR VALVE
- PWM driver for HEATER
- ON – OFF driver for SOL VALVE

## EXPERIMENT DESCRIPTION

### BASIC COURSE OF PROCESS CONTROL:

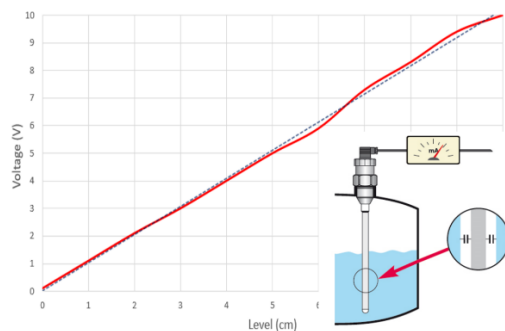

#### *Level sensor settings*

From the beginning of the experiments, the students will learn about different types of sensors. They learn how to calibrate and use a capacitive fluid level sensor in order to measure the water level and to determine the sensor characteristics.

The level transducer (L/U) is used to calibrate the level sensor for a correspondence of 1 V to 1 cm.

#### *Characteristics of the motor of the pump*

The experiment is very practical because they will learn what is the Control in PWM (Pulse Width Modulation) of a DC motor. Using a classical oscilloscope, the students will analyze the control signals of a pump motor. The reference input signal of the motor is a triangular 10Vpp while the duty cycle of PWM is modulated from the control panel of trainer.

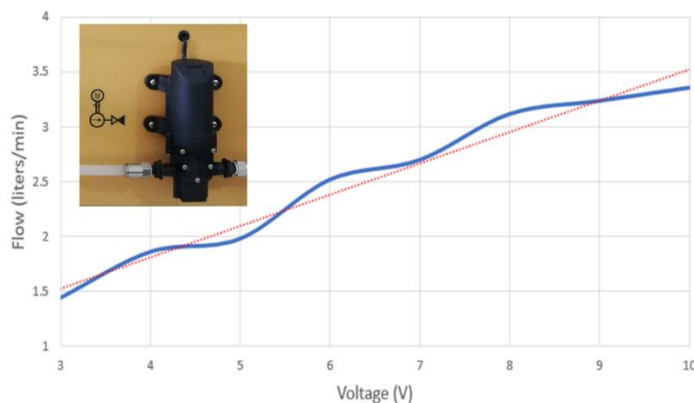
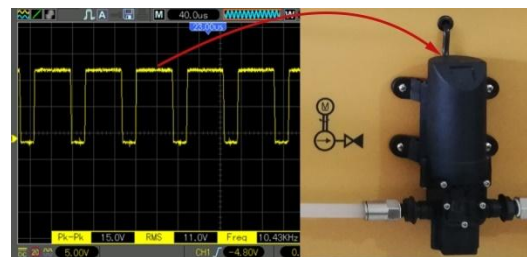

#### *Characteristics of the pump*

After running this experiment, the students will understand the working principle of a diaphragm pump. They will learn how to compute the flow and how to measure it using the flowmeter to draw the characteristic curve of pumps flow.



## Characteristics of the static process

Using the knowledge from the previous test, it will help to perform this test. The main objective is to understand how the flow will influence the rising time of the fluid level rate in a level control process.

The flow transducer (f/U) is used to calibrate the flow sensor for a correspondence of 1 V output to 0.5 liters per minute.

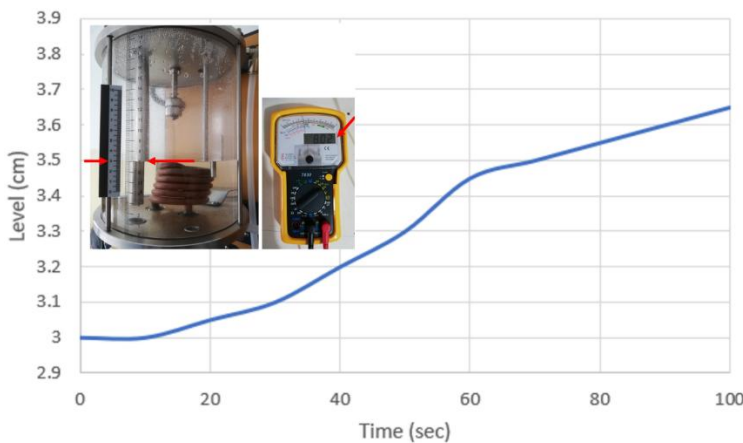
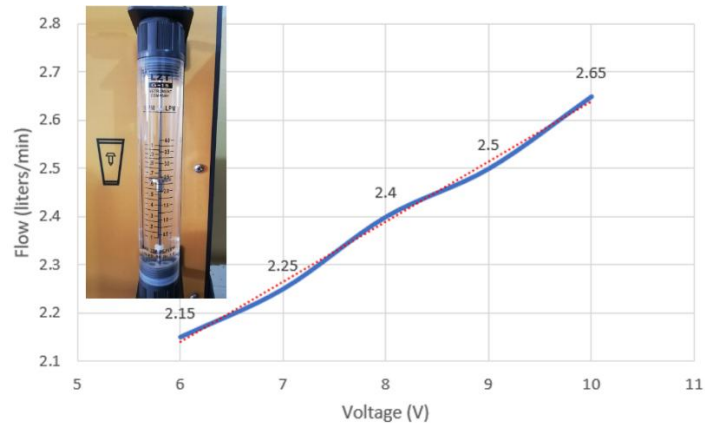

## Time constant of the process

What is the time constant of a process? How do they calculate it? The students can answer this question by performing this experiment. The time constant estimation is made up of the water flow in the tank, as a ratio between the input flow and the draining flow rate. This process is an example of parameter identification.

## ON - OFF control of the level

What are the effects of the hysteresis on the level control? The students will find out while learning how to measure the dynamic response of the process. They will use the capacitive level sensor to measure the water level in the process tank.

This knowledge is very important because in practical situations, one of the most widely used types of control is the ON/OFF control.

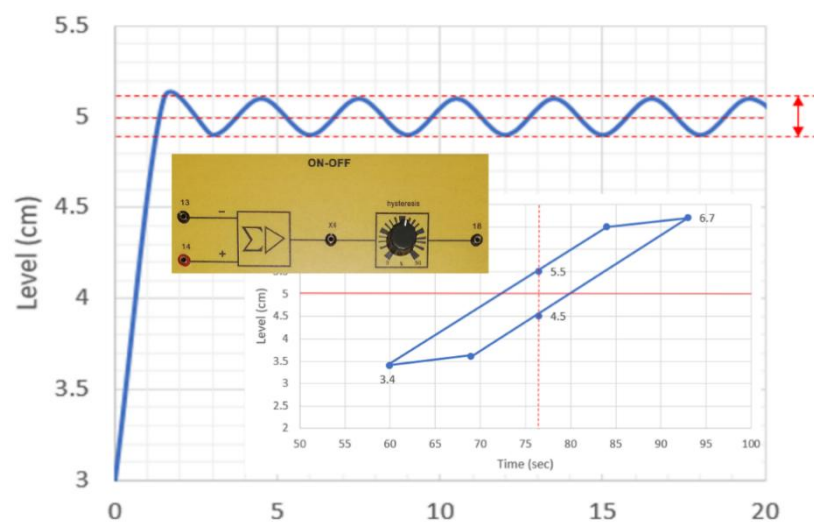

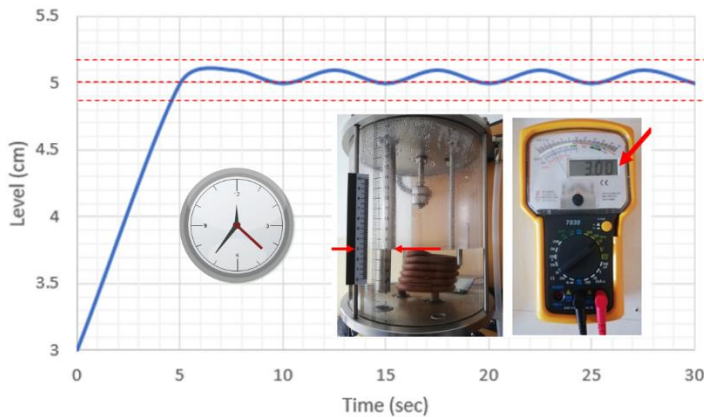

### **ON - OFF control of the level with "Sol Valve"**

In this experiment, the students will use their accumulated knowledge regarding the hysteresis on the level control. This will measure the upward and downward number of movements of the level between the "Start and Stop" of the electro-valve with a hysteresis of 0%, 15% and 30%.

### **ON - OFF control of the level with "Float Switch"**

Students will perform practical study to maintain a constant level in the tank using an "ON-OFF" level sensor and the electro sol valve.

They will learn how to measure the water level variation in time. To determine the hysteresis curve for "On - Off" control of the level, they use the engraved mobile scale or the level sensor and float switch.

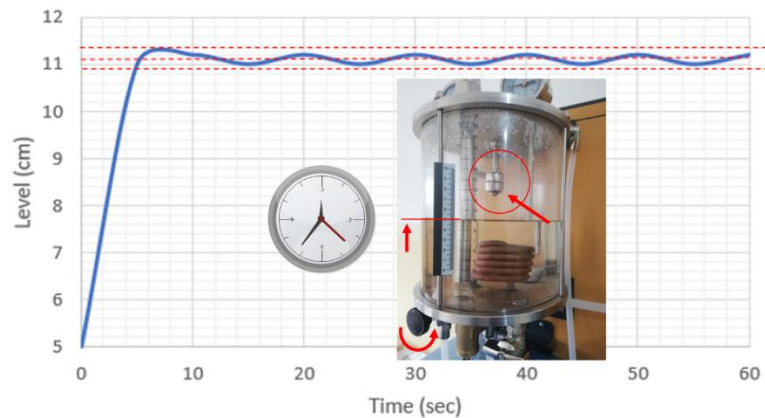

### **Closed loop control of the LEVEL**

#### **Closed loop Proportional control of the level**

#### **Closed loop Proportional-Integral control of the level**

#### **Closed loop Proportional-Derivative control of the level**

#### **Closed loop Proportional-Integral-Derivative control of the level**

To be able to study the closed loop control, first they need to check the effects of the gain loop on the dynamic response of the system. It is very interesting to observe the output characteristic of the PID controller for different  $K_p$ ,  $K_d$  and  $K_i$  constant values.

Ziegler-Nichols method is used in tuning of PID controller. The students learn how to determine the PID parameters to obtain the controlled level.

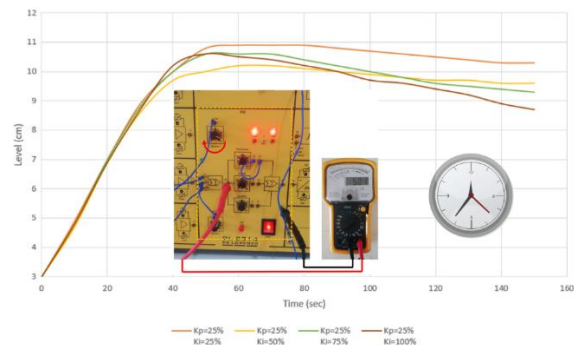



## Closed loop control of the FLOW

### Flow sensor

**Closed loop Proportional control of the flow**

**Closed loop Proportional-Integral control of the flow**

**Closed loop Proportional-Derivative control of the flow**

**Closed loop Proportional-Integral-Derivative control of flow**

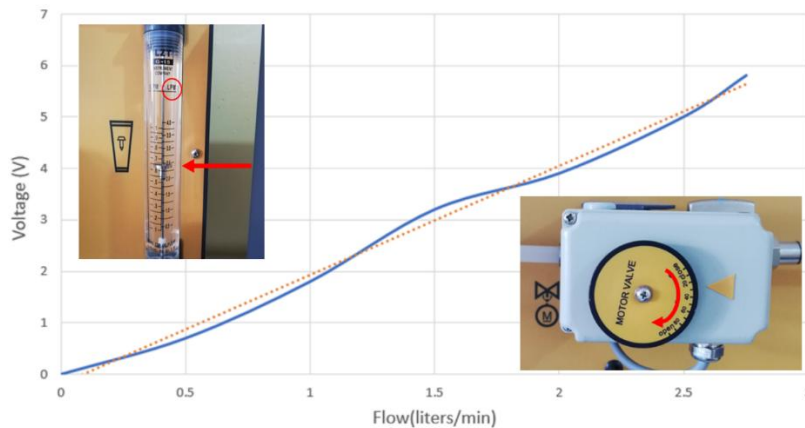

During these experiments, the students learn how to measure the water flow rate by using the engraved scale of the direct flow meter or the turbine flow sensor. After analyzing the results, they must be able to implement the tuning of the PID control of the system with optimum stability.

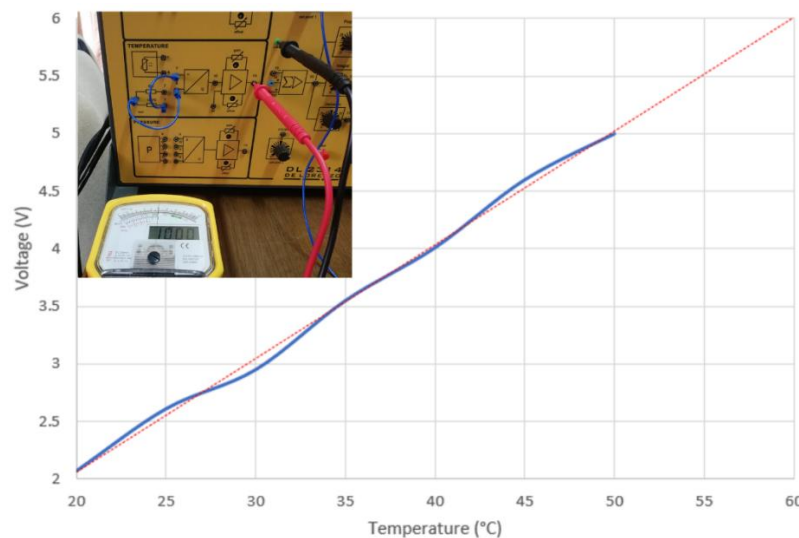

### Temperature sensor

The students learn how to measure the temperature variation in time, using the engraved thermometer scale or the temperature sensor, in order to determine and compute the characteristic curve of PT100 sensor (RDT). The temperature transducer (u/U) is used to calibrate the temperature sensor for a correspondence of 1 V to 10 degrees Celsius.



## Measurement of the characteristics of the heating

This experiment is similar with the previous one, but this time the students will understand the working principle of a resistive temperature sensor to measure the temperature in the industrial process tank. Using a classical oscilloscope, the students can analyze the waveform of the PWM for the heating element.

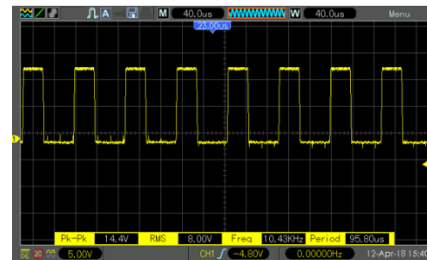
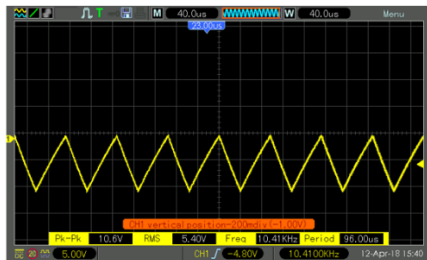
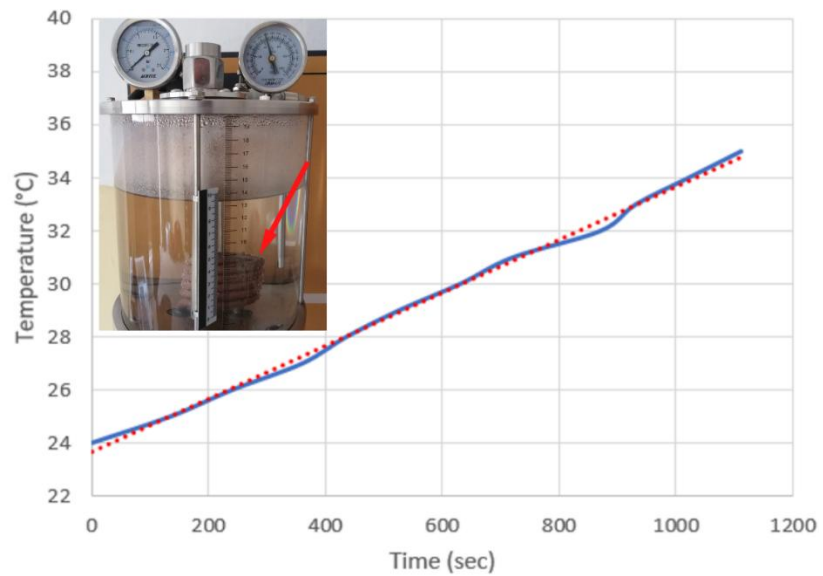

## Closed loop control of the TEMPERATURE

**Closed loop Proportional control of the temperature**

**Closed loop Proportional-Integral control of the temperature**

**Closed loop Proportional-Derivative control of the temperature**

**Closed loop Proportional-Integral-Derivative control of the temperature**

The students will learn that in a temperature controller system, the controller accepts a temperature sensor as an input, such as an RTD or thermocouple, and compares the actual temperature with the required control temperature or setpoint. The output is then provided to a control element.

After analyzing the results, they will be able to fine tune the PID control of the system.

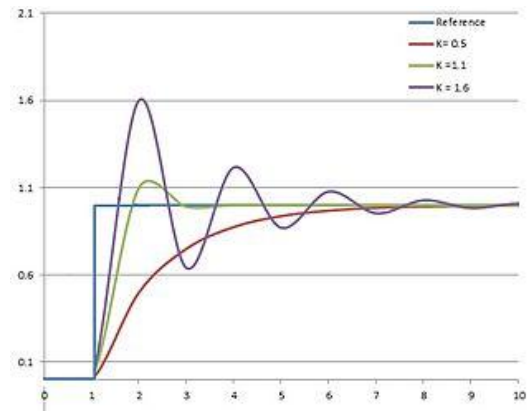



## **Pressure sensor**

The students will learn how to measure the pressure, using the electronic pressure sensor or pressure gauge scale, to determine and compute the characteristic curve of the pressure sensor.

The pressure transducer (P/U) is used to calibrate the pressure sensor for a correspondence of 1 V is 0.15 bar. The characteristics of a pressure transducer will be determined.

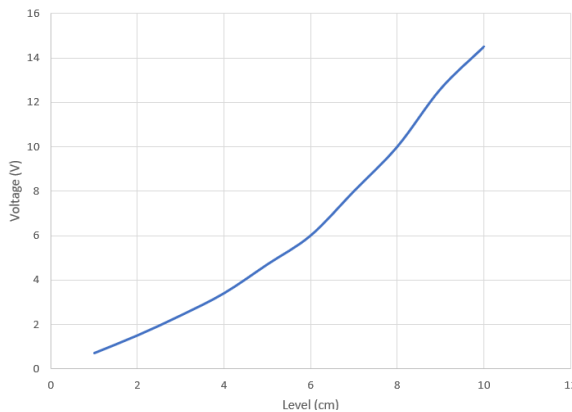
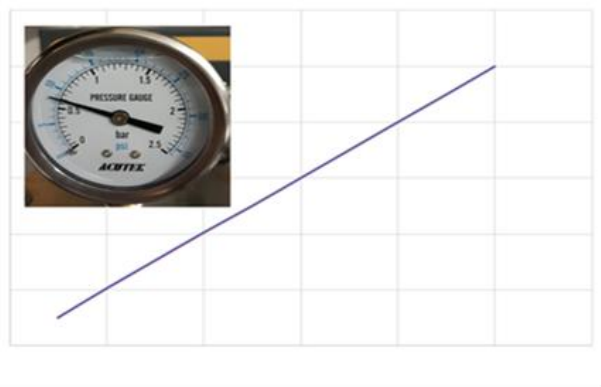

## **Pressure sensor as a level sensor**

The main objective of this experiment is measuring the pressure, using the electronic pressure sensor or pressure gauge scale, to determine the characteristic curve of the level vs. pressure response.

## **ON - OFF control of the level through the pressure sensor**

The students, already familiar with the procedure of "ON-OFF" control, will perform the operation of a closed loop "ON-OFF" control system using the pressure sensor as a level sensor.

The knowledge regarding the effects of the hysteresis on the control will be used in controlling the pressure.

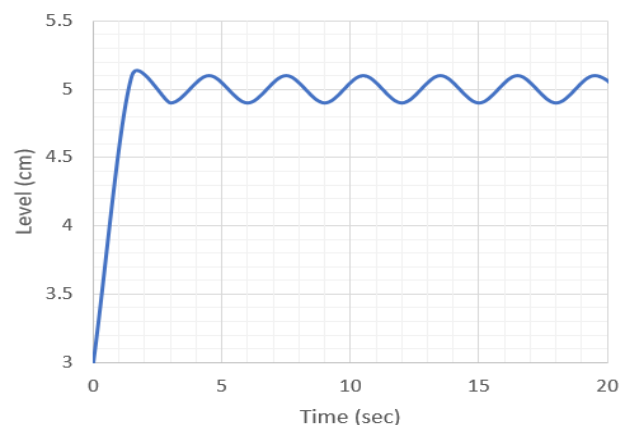



## BASIC COURSE OF PLC:

### Basic and Introductory PLC experiments:

Starting with these first experiments the students will focus on the PLC hardware fundamentals and logic programming with Siemens S7-1200. The experiments are a step-by-step introduction to PLC, guiding the students to create their first projects. This will give them the basic knowledge in solving real world problems in practical projects, about automation engineering and process control.

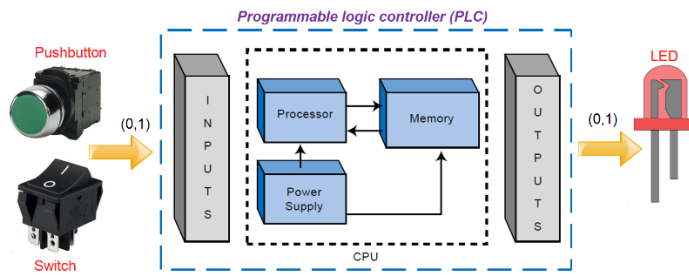

### PLC basic applications: ON - OFF control

The students learn basic elements of PLC functions by writing small programs and testing these programs on the trainer. This application is focused mostly on introductory operations in programming and using Step 7- 1200 architecture. It simulates ON - OFF commands from push buttons, and/or switches.

### PLC basic application: PWM control

This experiment is very practical because they will learn what is the control in PWM (Pulse Width Modulation). The digital input acts as a toggle switch. When the switch is on the output LED will flash with the programmed clock memory.

From the PLC training panel interface any of 14 Digital Inputs of the CPU 1214C can be used for this experiment.

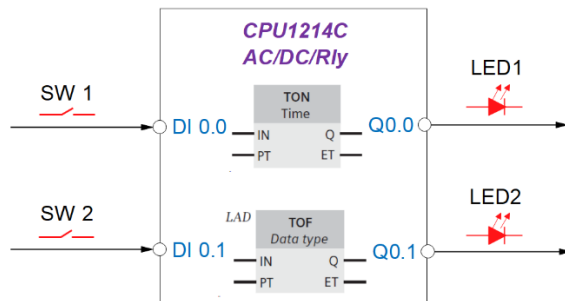
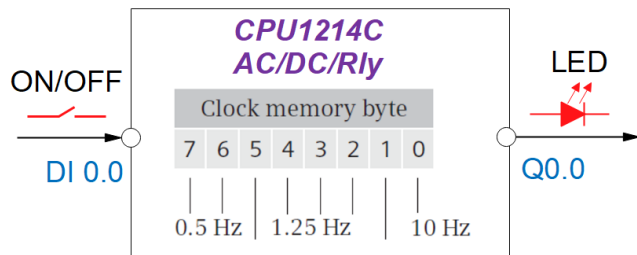

### PLC basic applications: Timer control

After running this experiment, the students will understand the working principle of a TON "Generate on-delay" and TOF "Generate off-delay" instructions. These instructions are used to operate an output for a certain time or wait a certain time before operating an output.



## PLC basic applications: Counter control

This experiment will give the knowledge of using the counter functions in performing process control experiments. Later in the manual the students will use this function to counter the number of times when a pressure in a water tank is reached.

They will understand the working principle of a CTU "Up counter" and CTD "Down counter" instructions.

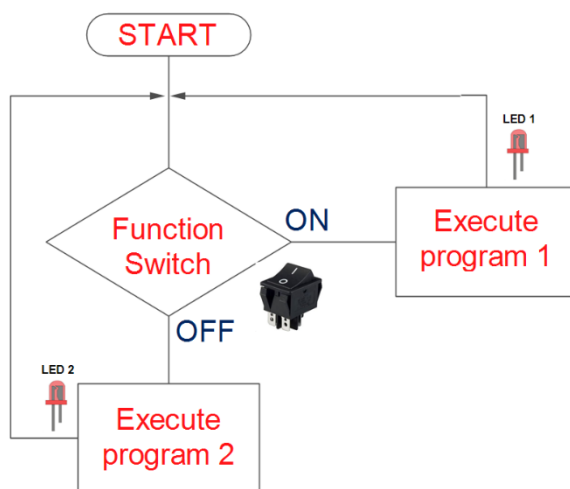
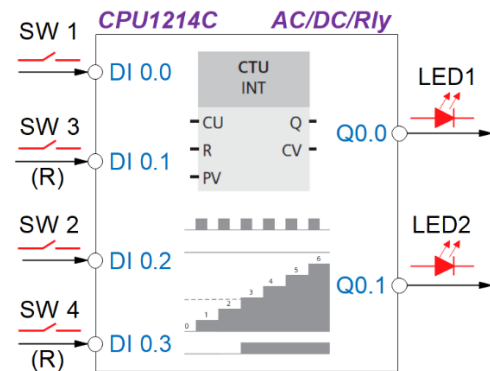

## PLC basic control applications: Two functions control

The main objective of this application is to introduce the students in how to approach an application that has multiple functional descriptions. For example, if you have a digital switch as an input in the PLC and based on the status of the switch, the PLC must execute a specific subroutine.

A function code block (FC) will be added to configure 2 functional programs.

## Advanced process control experiments:

The advanced applications combine the use of the process panel with the PLC. Using the TIA portal software, the students can understand the following concepts:

- Schematic diagram of the process
- Signal diagram of the process
- Flowchart of the automatization process
- Laboratory wiring diagram



## Level control system. Pumping water station

This first automatic process control experiment studies a pumping water station. The PLC then will control the flow of water into the water tank.

One method to adjust the control level thresholds is using the capacitance probe included in the process control trainer. The probe will monitor the level, with control points adjusted by the PLC.

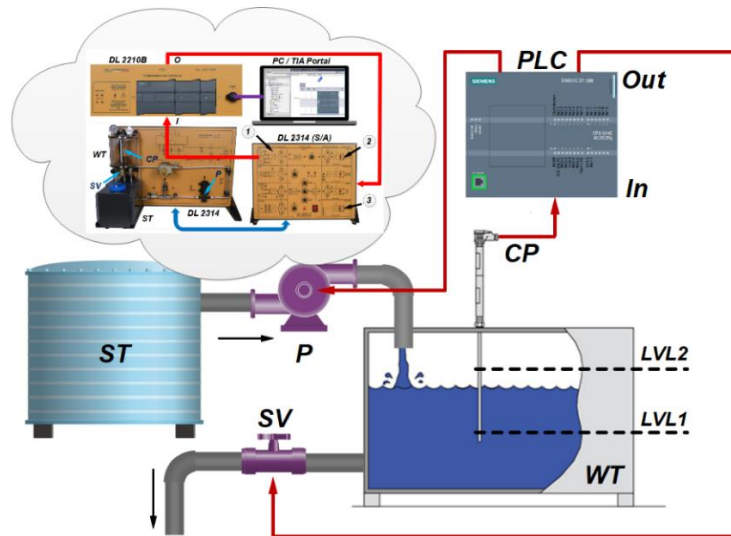

## Level control system with time response. Liquid solvent distribution system

This experiment introduces the students to a control system with time response. An example of real automated system is a liquid solvent distribution system located in a factory. Its purpose is to release the solvent into the system after the product, in a process vessel, has been emptied until a certain level.

The students can change the proposed delay using the knowledge from the previous experiments.

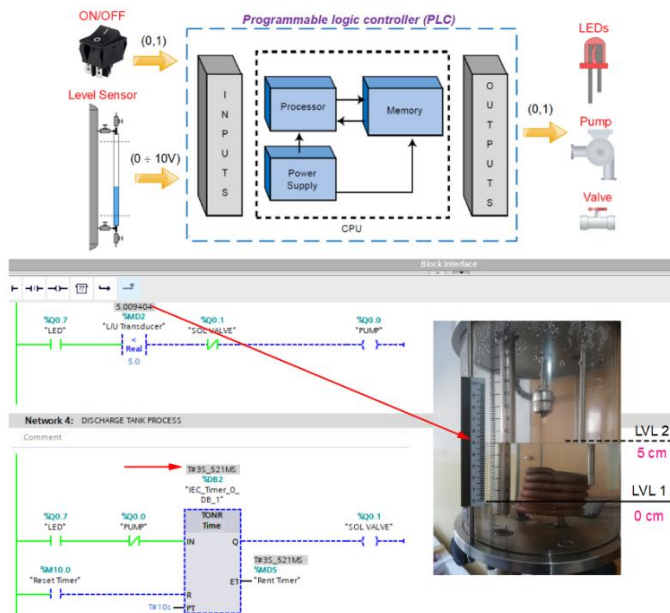



## Temperature control system. Heating water station

Comparing with the previous experiments, a second analogue input will be added to the PLC. The temperature process control experiment presents the principles of single-loop control by calibration of sensors and tuning of PLC for ON - OFF temperature control. The heater element will heat the water until a predefined value of temperature.

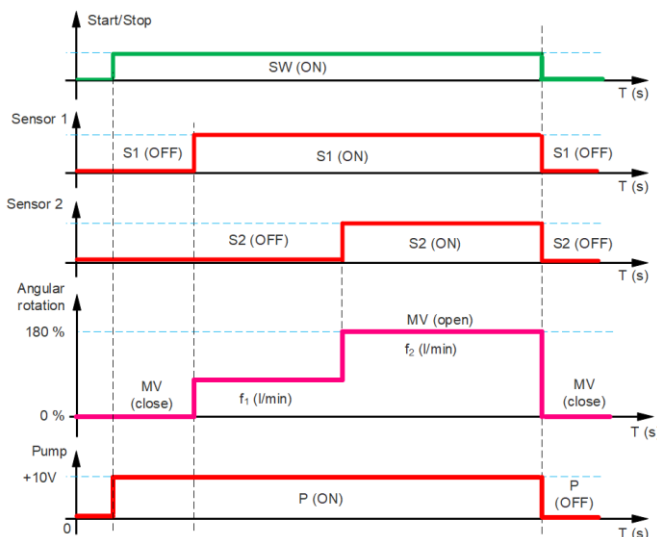
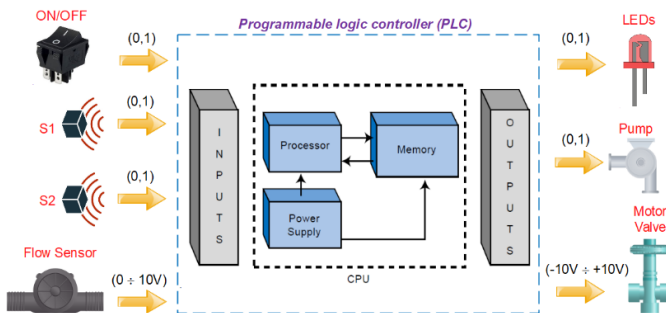
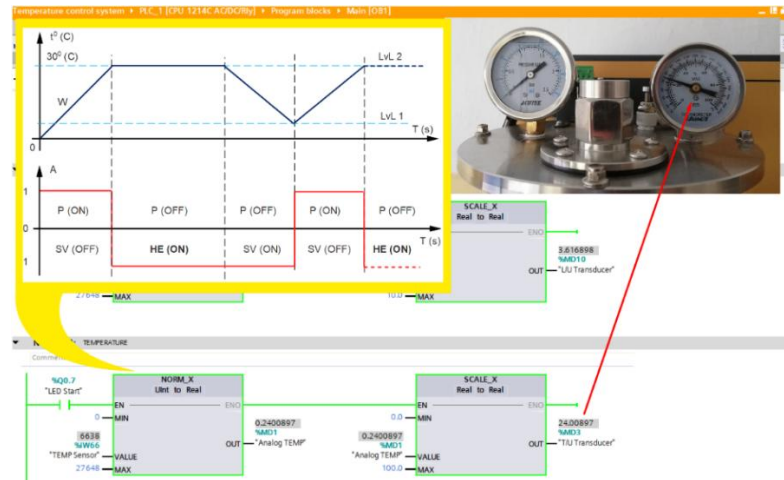

## Flow control system. Liquid distribution system with constant-flow pump

A flow control system is a liquid distribution system with constant-flow pump for filling water bottles that have 2 different volumes. The PLC ensure a low flow rate  $f_1$  when, on the conveyor belt, there is a small water bottle and a high flow rate  $f_2$  when on the conveyor belt there is a big water bottle.

The PLC purpose is to turn the pump ON and OFF and to control a motor valve to regulate the rate flow. Flow sensor that measures the flow is located on the water pipe.

The flow transducer is connected to the analog input (AI 0.0) of the PLC. The flow transducer output corresponds to 1 V output at 0.5 liters per minute.



## **Pressure control system with fast time response. Pressure cleaning station**

In this application the students will develop an on/off pressure controller (also known as a hysteresis controller). This is a feedback controller that switches abruptly between two states. In the experiment, it is described the functionality of a pressure cleaning station for solar panels. Its purpose is to release the cleaning solution to the solar panels (SP) after the product in a water tank (WT) has been filled until a certain level of pressure. As the solvent flows through connecting pipes it cleans a set of 3 solar panels in preparation for the next set.

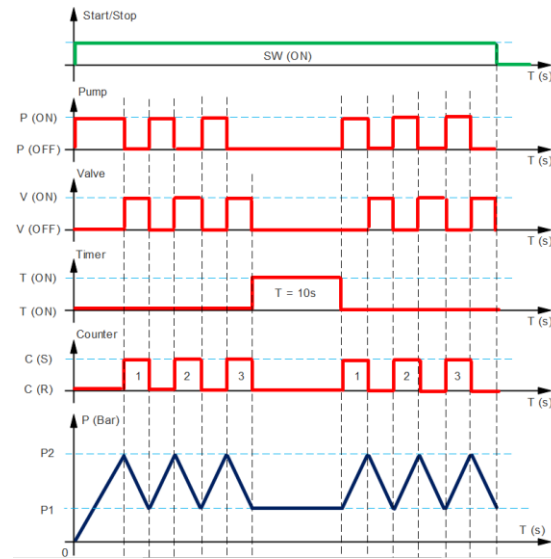

## **PID system with slow time response.**

### **Closed loop PID control of level**

The students will learn how to perform the wiring connections of the DL 2314 Input, Output and PID Controller interfaces in order to control the water level in the process tank.

They can tune the PID manually by using different P, I and D values, and can easily test how P control, P-I control, P-D control reacts to the same setup of the trainer.

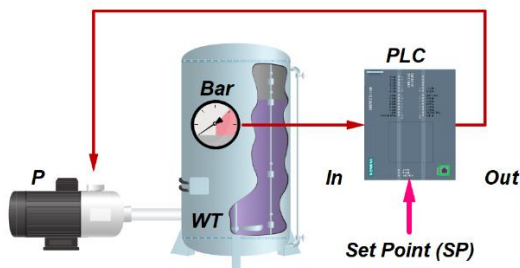
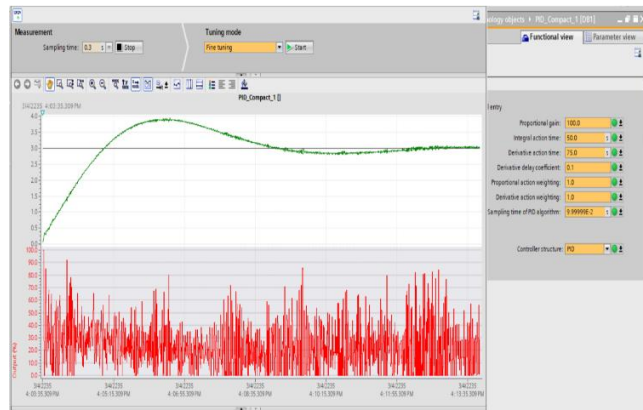

## **PID system with fast time response. Closed loop PID control of pressure**

The main objective of this experiment is measuring the pressure. The students will learn how to perform the pre-tuning and fine tuning of the PID controller.

With the technology objects for PID control, they create control loops with PID response and integrated optimization in manual and automatic mode.