



INDEX

POWER SUPPLIES

DC POWER SUPPLY
AC POWER SUPPLY
POWER SUPPLY FOR DIGITAL ELECTRONICS
POWER SUPPLY

DL 2555ALG
DL 2555ALS
DL 2203DB
DL 1004

DISCRETE COMPONENTS LINEAR ELECTRONICS

BJT VOLTAGE AMPLIFIERS
BJT POWER AMPLIFIERS
BJT FEEDBACK AMPLIFIERS
FET-MOSFET
TRANSISTOR BASED VOLTAGE REGULATORS

DL 2155AT
DL 2155APT
DL 2155ART
DL 2155FET
DL 2155RTD

INTEGRATED COMPONENTS LINEAR ELECTRONICS

TRANSISTOR MULTIVIBRATORS
SCHMITT TRIGGER AND NE555
OPERATIONAL AMPLIFIERS
ACTIVE FILTERS
FUNCTION GENERATORS
DIFFERENTIATORS, INTEGRATORS, SAMPLE AND HOLD
CIRCUITS AND PEAK DETECTORS
COMPARATORS
AC AMPLIFIERS AND DC INSTRUMENT AMPLIFIERS
ANALOG SWITCHES AND MULTIPLEXERS
VOLTAGE REGULATORS WITH INTEGRATED CIRCUITS
DIGITAL-TO-ANALOGUE CONVERTERS
ANALOGUE-TO-DIGITAL CONVERTERS

DL 2155MVB
DL 2155TRG
DL 2155AOP
DL 2155FIL
DL 2155GEF
DL 2155DIS

DL 2155COM
DL 2155AMP
DL 2155SMA
DL 2155RTI
DL 2155DAC
DL 2155ADC

APPLICATIONS

SWITCHING POWER SUPPLIES
THYRISTORS, TRIACS AND THEIR APPLICATIONS
TEMPERATURE CONTROL
SPEED CONTROL OF A DC MOTOR
STEP MOTOR CONTROL
PROCESS SIMULATOR WITH PID CONTROL
POWER ELECTRONICS BOARD
MOTOR BOARD

DL 2155AC
DL 2316
DL 2155RGT
DL 2155RGM
DL 2208
DL 2330
DL 2317SR
DL 2318SR

DIGITAL ELECTRONICS

COMBINATORY LOGIC
SEQUENTIAL LOGIC
HCT – ECL – CMOS
ADVANCED SEQUENTIAL LOGIC
PROGRAMMABLE LOGIC
DIGITAL BOARD

DL 2203C
DL 2203S
DL 2203SFL
DL 2205INL
DL 2205PRL
DL 2203SR



			POWER SUPPLIES			
CODE	BOARD		DL 2555ALG	DL 2555 ALS	DL 2203 DB	MAINS SUPPLY
DISCRETE COMPONENTS LINEAR ELECTRONICS						
DL 2155AT	BJT voltage amplifiers		X			
DL 2155APT	BJT power amplifiers		X			
DL 2155ART	BJT feedback amplifiers		X			
DL 2155FET	FET-MOSFET		X			
DL 2155RTD	Voltage regulators		X			
INTEGRATED COMPONENTS LINEAR ELECTRONICS						
DL 2155MVB	Transistor multivibrators		X			
DL 2155TRG	Schmitt trigger and NE 555		X			
DL 2155AOP	Operational amplifiers		X			
DL 2155FIL	Active filters		X			
DL 2155GEF	Function generators		X			
DL 2155DIS	Differentiators, integrators...		X			
DL 2155COM	Comparators		X			
DL 2155AMP	AC and DC amplifiers		X			
DL 2155SMA	Analogue switches, multiplexers		X			
DL 2155RTI	Voltage regulators		X			
APPLICATIONS						
DL 2155DAC	Digital-analogue converters		X			
DL 2155ADC	Analogue-digital converters		X			
DL 2155AC	Switching power supplies			X		
DL 2316	Thyristors, triacs, ...		X	X		
DL 2155RGT	Temperature control		X	X		
DL 2155RGM	DC motor speed control		X	X		
DL 2208	Step motor control					X
DL 2330	Process simulator with PID		X			
DL 2317SR	Power electronics board					X
DL 2318SR	Motor board					X
DIGITAL ELECTRONICS						
DL 2203C	Combinatory logic				X	
DL 2203S	Sequential logic				X	
DL 2203SFL	HCT-ECL-CMOS				X	
DL 2205INL	Advanced sequential logic				X	
DL 2205PRL	Programmable logic				X	
DL 2203SR	Digital board					X



POWER SUPPLIES

DC Power Supply



DL 2555ALG

The module gives the direct power supplies that are necessary for the operation of the experiment boards.

Output voltages

- ± 15 Vdc, 1 A
- ± 5 Vdc, 1 A

protection against short circuits

Supply voltage: single-phase from mains.

AC Power Supply



DL 2555ALS

The module gives the alternating power supplies that are necessary for the operation of the experiment boards.

Output voltages

- 12 Vac, 2 A
- 24 Vac, 2 A

Supply voltage: single-phase from mains.



Power Supply for Digital Electronics

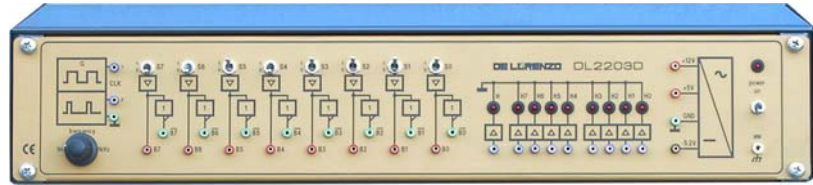

DL 2203DB

It supplies the power necessary for the operation of the boards of digital electronics.

Technical features:

- 3 stabilized and protected dc outputs
- +12V/500mA, +5V/2A, -5.2V/500mA
- 1 CLK1 square wave generator, 5V amplitude, variable frequency from 1Hz to 1kHz
- 1 CLK2 pulse generator, 5V amplitude, variable frequency from 1Hz to 1kHz, rise edge synchronized with CLK1
- 8 logic variable (true and false) generators
- 9 LED for visualization of the logic states

Power supply: single phase from mains

Power Supply



DL 1004

Designed for electronics laboratories. Its main purpose is to realize a power supply source with high safety features and remarkable electric performance.

Output voltages:

- 2 independent stabilized supplies: 0÷30V, 0÷2 A, complete with digital instrument for voltage and current. Possibility of tracking.
- Fixed dual supply: ± 5V/1A
- Fixed dual supply: ± 12V/1A
- Fixed dual supply: ± 24V/1A
- 2 ac power supplies: 0÷250V/1A and 0÷25V/2A isolated from the mains
- Series of sockets: 220 V, 10/16A

The output connecting terminals are of unloseable type. The outputs are protected by means of a general magnetothermal-differential switch.

Supply voltage: single-phase from mains.



DISCRETE COMPONENTS LINEAR ELECTRONICS

BJT voltage amplifiers

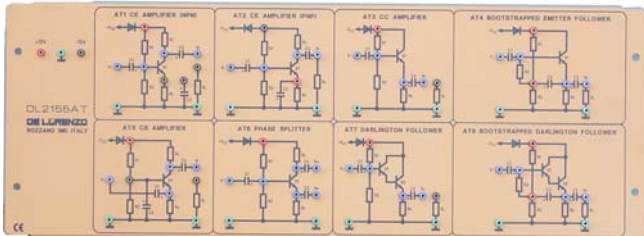

DL 2155AT

Experiments

- Bias and dc load line in CE, CC and CB configurations
- Measurement of typical parameters in the three configurations
- Dual load amplifier with phase inverter function
- Emitter follower and bootstrap effect bias
- Analysis and checking of Darlington connection

The board allows a first approach to the theoretical-practical study of the static and dynamic operation of the BJT (Base-emitter Junction Transistor), used as a voltage amplifier.

The board affords the problems associated to the use of the transistors in the three basic configurations: CE (Common Emitter), CC (Common Collector) and CB (Common Base).

Firstly, the bias and the working point stabilization problems are considered.

Then, the typical features of the three configurations are analyzed: input resistance, output resistance, voltage gain and current gain.

In the second section of the board typical applications are studied, such as the bootstrap effect bias and the Darlington connection.

The board is supplied complete with a set of stackable, plug-in cables of suitable lengths and colours and with a training manual.

Power supply: ± 15 Vdc, 250 mA

BJT power amplifiers

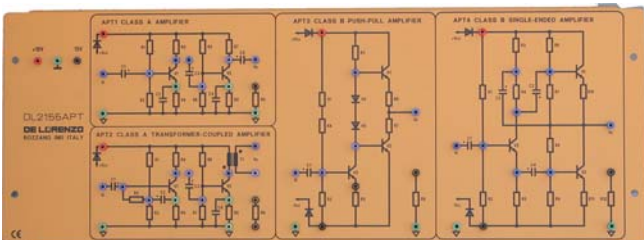

DL 2155APT

Experiments

- Checking the conversion efficiency and the figure of merit in a A-class amplifier with dc current flowing through the load
- Determination of the typical parameters of a A-class amplifier with an output transformer
- Checking the characteristics of a complementary symmetry push-pull amplifier
- Checking the characteristics of the single-ended amplifier

The board represents an extremely useful tool for studying the power amplifier of A class and B class.

In fact, it provides 4 amplification architectures among the most common in preamplifiers (A class) and final amplifiers (B class), with the possibility of analyzing the power stage and/or the drivers.

The board is supplied complete with a set of stackable, plug-in cables of suitable lengths and colours and with a training manual.

Power supply: ± 15 Vdc, 1 A



BJT Feedback amplifiers

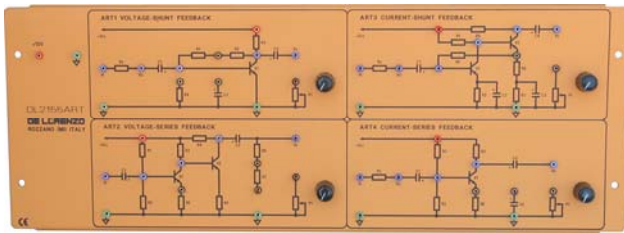

DL 2155ART

Experiments

- Analysis and study of an amplifier with series or parallel voltage feedback and with series or parallel current feedback
- Analysis and study of multistage amplifiers with direct coupling
- Influence of feedback in the amplifier: study of the amplifier with connected/unconnected feedback

The board is designed to afford the problems connected to the introduction of negative feedback into an amplifier, and to its influence on the different parameters: amplification, bandwidth, input and output resistances, noise.

The different feedback configurations are theoretically analyzed and experimentally checked: series voltage, parallel voltage, series current, parallel current.

Single stage and multistage amplifiers are used, the latter in direct coupling.

The board is supplied complete with a set of stackable, plug-in cables of suitable lengths and colours and with a training manual.

Power supply: + 15 Vdc, 750 mA

FET-MOSFET

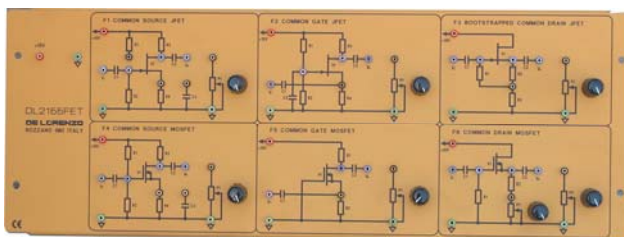

DL 2155FET

Experiments

- FET and MOSFET bias in the different configurations
- Measurement of typical configuration parameters
- Bootstrap effect in common drain configuration

The board provides a full support concerning the elementary amplification configurations. It affords the problems related to the use of FET and MOSFET in the three basic configurations: common source, gate and drain. Firstly, the bias and working point stabilization problems are considered. Then, the typical features of the configurations are analyzed: voltage gain, input and output resistances.

The board is supplied complete with a set of stackable, plug-in cables of suitable lengths and colours and with a training manual.

Power supply: + 15 Vdc, 750 mA



Transistor Based Voltage Regulators

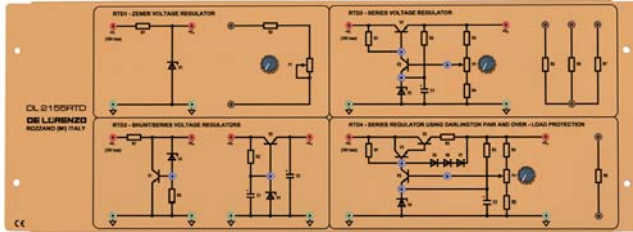

DL 2155RTD

Experiments

- Study of voltage regulators with fixed or adjustable output voltage
- Study of different regulators with increasing performances
- Measurement of the typical regulator parameters: input and output characteristics, output resistance, ripple

The board analyzes the components normally used in cascade to transformer and filter to realize stabilized power supply units with bipolar technology.

For all configurations the input and output characteristics can be measured.

The board is arranged in 4 modules that allow the study of:

- Zener voltage regulator
- Zener voltage regulator with series and parallel transistor
- Voltage regulator with variable output
- Voltage regulator with short-circuit protection and Darlington transistor

The board is supplied complete with a set of stackable, plug-in cables of suitable lengths and colours and with a training manual.

Power supply: + 15 Vdc, 750 mA



INTEGRATED COMPONENTS LINEAR ELECTRONICS

Transistor Multivibrators

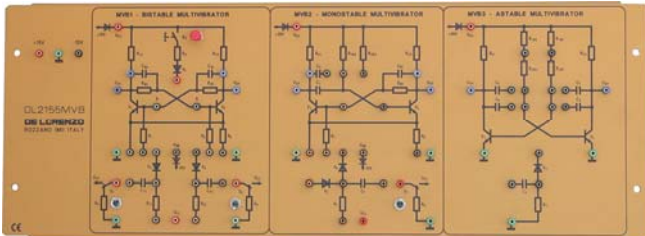

DL 2155MVB

Experiments

- Analysis of the bistable multivibrator with fixed and self bias
- Check of set, reset and trigger controls operation
- Analysis of the monostable multivibrator with fixed and self bias
- Check of the trigger control
- Analysis of the astable multivibrator

The board is designed to study and experimentally check the most popular configurations of transistor-based multivibrating circuits.

The board is divided into three main sections. The first section deals with bistable multivibrators in fixed bias and self-biased configurations.

The various set, reset and trigger controls are analyzed. The second section affords the study of monostable multivibrators with fixed bias and self bias and the relevant controls. The third section is dedicated to the astable multivibrators.

The board is supplied complete with a set of stackable, plug-in cables of suitable lengths and colours and with a training manual.

Power supply: ± 15 Vdc, 100 mA

Schmitt Trigger and NE555

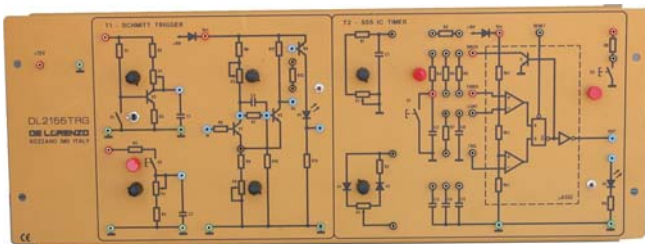

DL 2155TRG

Experiments

- Analysis and study of Schmitt trigger operation
- Use of Schmitt trigger as threshold detector and clipper
- Analysis of the block diagram of NE 555 integrated circuit
- Use of NE 555 as astable and monostable multivibrator

The board allows to analyze the operation of Schmitt trigger and NE 555 integrated circuit.

It is composed of two sections.

The first section allows the study and the experimental checking of the Schmitt trigger. Also two typical applications of this circuit are analyzed: threshold detector and clipper.

The second section is dedicated to the study of the 555 integrated circuit.

This is a flexible and widely used integrated circuit. It is used to generate delays, pulse trains and adjustable duty-cycle square waves.

The board allows to analyze the block diagram and to experimentally check the most widespread applications. The board is supplied complete with a set of stackable, plug-in suitable lengths and colours and with a training manual.

Power supply: + 15 Vdc, 50 mA



Operational Amplifiers

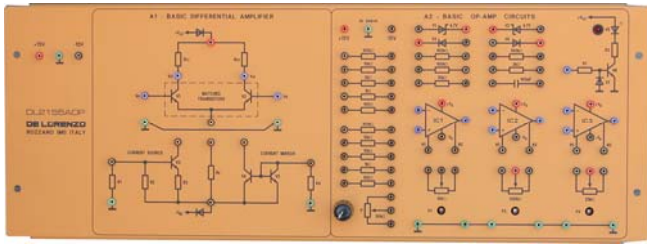

DL 2155AOP

Experiments

- Analysis and experimental check of differential mode amplification in a differential amplifier
- Measurement of CMRR and of slew rate
- Analysis and measurement of fixed and adjustable gain inverting amplifiers
- Analysis and measurement of fixed and adjustable gain non-inverting amplifiers
- Comparison and analysis of application fields of different amplifiers
- Study of application circuits with operational amplifiers

The board is designed for a first approach to operational amplifiers. It is divided in two sections. The first section includes a transistor based differential amplifier and allows the general and full study of the input stage of a monolithic operational amplifier. The concepts of inverting and non-inverting inputs, common mode and differential amplification and common mode feedback are considered.

The second section shows three different monolithic operational amplifiers and a set of active and passive components, allowing to check and to compare the features of the three amplifiers and the study of the different application fields.

The board is supplied complete with a set of stackable, plug-in cables of suitable lengths and colours and with a training manual.

Power supply: ± 15 Vdc, 750 mA

Active Filters

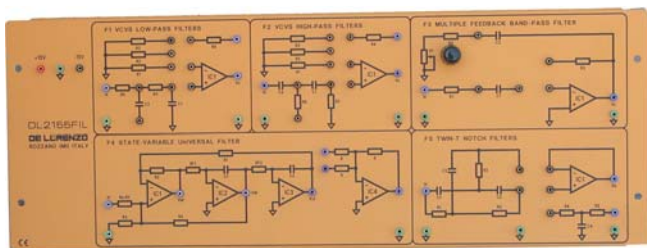

DL 2155FIL

Experiments

- Low-pass and high-pass filters of the first and second order with Butterworth, Bessel and Chebyshev approximation
- Multiple feedback band-pass filters
- High-pass, low-pass, band-pass and throw-band filters of variable state type
- Dual T narrow-band notch filters

The board allows the study and the functional check on active filters carried out with operational amplifiers. The board is divided in five sections, and in each one there are more than one filter of the same kind. It is possible to study, respectively:

- low-pass filter VCVS of the first and second order
- high-pass filter VCVS of the first and second order
- multiple feedback band-pass filter
- universal filter of variable-state type
- dual T band-stop filters

The board is supplied complete with a set of stackable, plug-in cables of suitable lengths and colours and with a training manual.

Power supply: ± 15 Vdc, 750 mA



Function Generators

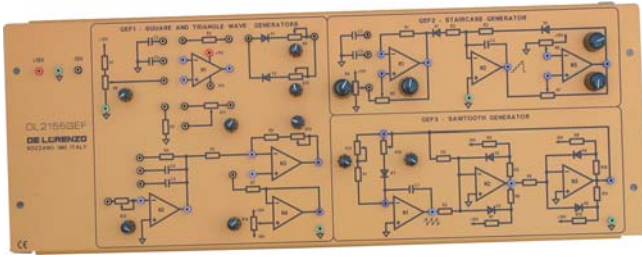

DL 2155GEF

Experiments

- Analysis of square wave and pulse generators with variable duty-cycle
- Analysis of square wave and triangular wave generators, with frequency, amplitude and offset adjustment
- Analysis of step wave generators
- Analysis of saw-tooth wave generators

The board allows to perform functional checking of the simplest and most popular square wave generators, pulse generators, triangular wave generators, saw tooth generators and step generators. All generators are realized with operational amplifiers. For some generators circuital arrangements have been used to allow adjustment of output signal frequency, duty-cycle, slope and offset.

It is therefore possible to perform an in depth study of increasing difficulty and complexity level of the function generator circuits.

The board is supplied complete with a set of stackable, plug-in cables of suitable lengths and colours and with a training manual.

Power supply: ± 15 Vdc, 750 mA

Differentiators, Integrators, Sample and Hold Circuits and Peak Detectors

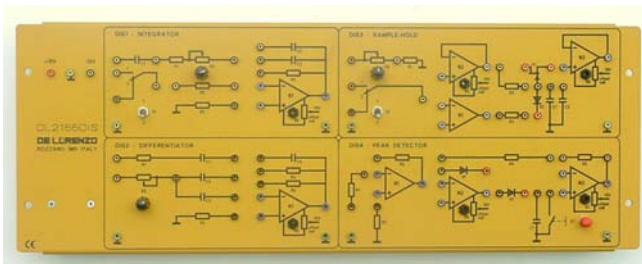

DL 2155DIS

Experiments

- Analysis of the operation of an active differentiator circuit
- Analysis of the operation of an active integrator circuit
- Response of integrator and differentiator circuits to dc, square-wave and sinusoidal signals
- Analysis of the operation of a sample-hold circuit
- Analysis of the operation of a positive and negative peak detector with open and closed loop

The board is designed to analyze important circuits for analogue signal processing which are widely used in process controls.

In particular, it is possible to analyze circuits for signal acquisition like sample-holds or peak detectors and circuits for signal processing like differentiators and integrators.

The board is supplied complete with a set of stackable, plug-in cables of suitable lengths and colours and with a training manual.

Power supply: ± 15 Vdc, 750 mA



Comparators

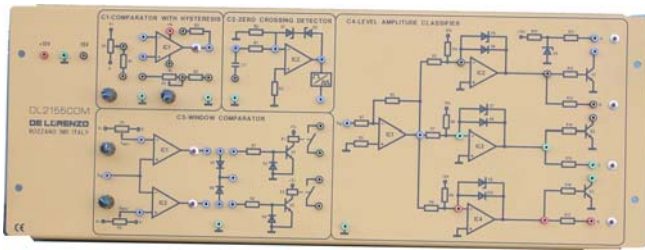

DL 2155COM

Experiments

- Analysis and checking of symmetrical and asymmetrical hysteresis cycle comparators
- Analysis and checking of zero crossing detector and window comparator
- Analysis of amplitude detecting circuits with logic output decoding
- Analysis and checking of inverting and non inverting voltage comparators

The board is designed to study the operating principle of voltage comparators and to perform experimental checking of the most popular and important circuits realized with these components.

The board is divided into four sections for the study of, respectively:

- hysteresis comparator
- zero crossing detector
- window comparator
- amplitude level classifier

The outputs of the comparators are provided with LED to show their electrical state.

The board is supplied complete with a set of stackable, plug-in cables of suitable lengths and colours and with a training manual.

Power supply: ± 15 Vdc, 750 mA

AC Amplifiers and DC Instrument Amplifiers

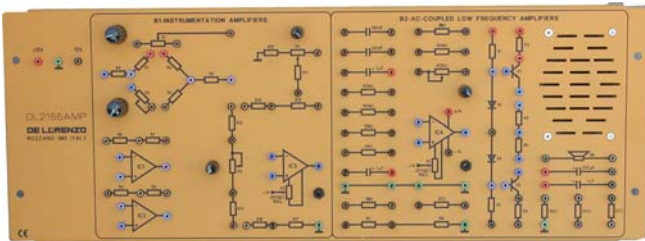

DL 2155AMP

Experiments

- Analysis and checking of an AC inverting amplifier with single and dual supply
- Analysis and checking of high input impedance differential amplifiers and balanced bridge input amplifiers
- Analysis and checking of AC adding and differential amplifiers
- Analysis and checking of audio and power amplifiers

The board is arranged in two separate sections allowing the study of DC instrument amplifiers and AC signal and power amplifiers.

The first section includes three amplifiers allowing the realization of different configurations of DC differential amplifiers with high input impedance.

The same section also includes several resistances and a potentiometer for connection to a Wheatstone bridge for functional checking of balanced input amplifiers.

The second section includes active and passive components that allow the realization of different signal amplifier circuits.

Moreover the board includes a power amplifier realized with a complementary symmetry reverse phase transistor.

The board is supplied complete with a set of stackable, plug-in cables of suitable lengths and colours and with a training manual.

Power supply: ± 15 Vdc, 750 mA



Analog Switches and Multiplexers

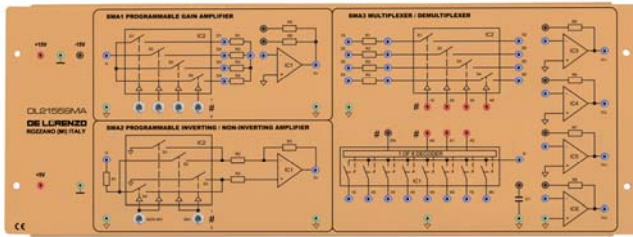

DL 2155SMA

The board is designed to study the problems related to the application of analog switches. These switches, and the multiplexers, find a wide application in data acquisition systems, telephone systems, process controls and in all the situations where low power signals have to be switched with high switching speed. The board is supplied complete with a set of stackable, plug-in cables of suitable lengths and colours and with a training manual.

Power supply: ± 15 Vdc and + 5 Vdc, 750 mA

Experiments

- Analysis of analogue switches operations and performances
- Analysis of some typical applications of analogue switches as adjustable gain amplifiers, inverting/non inverting configuration, programmable amplifiers and programmable attenuators
- Analysis of a multiplexer with four analogue inputs
- Analysis of a demultiplexer with four analogue outputs

Voltage Regulators with Integrated Circuits

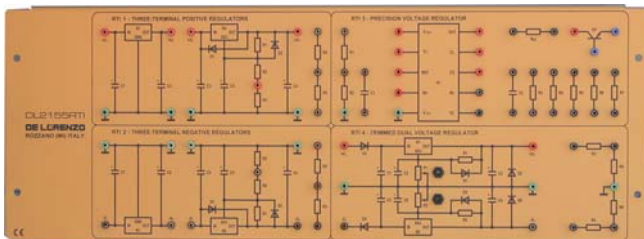

DL 2155RTI

The board is designed to study the regulators, in particular the voltage regulators, with integrated circuits.

The board is arranged into several modules that allow the study of three terminals positive and negative voltage regulators with either fixed or adjustable output voltage.

Then, a dual voltage regulator and a general-purpose regulator integrated circuit are analyzed.

The board is supplied complete with a set of stackable, plug-in cables of suitable lengths and colours and with a training manual.

Power supply: ± 15 Vdc, 750 mA

Experiments

- Analysis and functional checking of a three-terminals positive/negative voltage regulator with fixed output
- Adjustment of output voltage in three-terminals regulators
- Analysis and functional checking of a dual voltage regulator with separately adjustable voltages
- Measurements of input and output characteristics of previous regulators
- Analysis and operating modalities of a general-purpose monolithic regulator



Digital-To-Analogue Converters

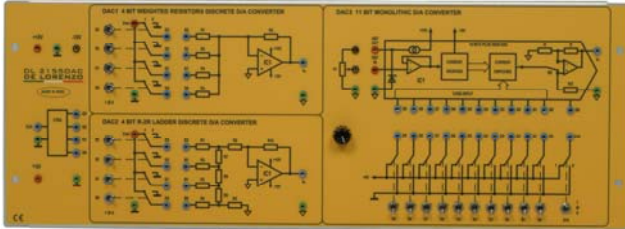

DL 2155DAC

Experiments

- Analysis of the operation of a weighed resistances converter
- Analysis of the operation of a converter in a R-2R network
- Analysis of the conversion errors
- Analysis of the operation and of the main characteristics of a monolithic converter

This board allows the study of the operating principle and of the main characteristics of a digital-to-analogue converter.

The board is composed of 3 independent sections:

- a weighed resistances discrete components D/A converter
- a discrete components D/A converter in a R-2R network
- a monolithic 11 bit D/A converter

While the first two sections are used to highlight the operating principle of two different D/A converters, the third one is used to analyse the operating modes and the characteristics of the converters that are commercially available.

The board is supplied complete with a set of stackable, plug-in cables of suitable lengths and colours and with a training manual.

Power supply: ± 15 Vdc, 200 mA and + 5Vdc, 200mA

Analogue-To-Digital Converters

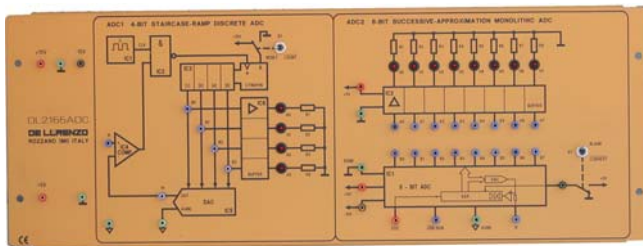

DL 2155ADC

Experiments

- Analysis of the operation of a counter converter
- Analysis of the operation and of the main characteristics of a monolithic converter
- Analysis of the conversion errors

This board allows the study of the operating principle and of the main characteristics of analogue-to-digital converters.

The board is divided in 2 sections: in the first one a discrete component realization is provided of a ramp A/D counter converter, while in the second section there is a monolithic converter.

The first section is used to highlight the operating principle of an A/D converter, while the second one is mainly used to analyse the operating modes and the characteristics of the converters that are commercially available.

The board is supplied complete with a set of stackable, plug-in cables of suitable lengths and colours and with a training manual.

Power supply: ± 15 Vdc, 100 mA and + 5Vdc, 200mA



APPLICATIONS

Switching Power Supplies

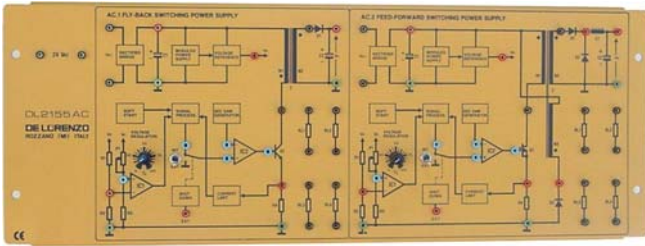

DL 2155AC

Experiments

- Analysis of the operation of a flyback power supply
- Analysis of the operation of a feed-forward power supply
- Regulation of the output voltage as a function of the load or of the input voltage
- Limitation characteristics
- Detection of the typical parameters of the power supplies (ripple voltage, efficiency, etc.)

During the latest years the switching power supplies technology has been significantly developed due to the features of smaller size and higher efficiency of these power supplies when compared to the traditional ones.

This board is basically composed of two sections:

- a BJT-based flyback power supply, with output voltage adjustable from 12V to 18V by means of a potentiometer and rated current 0.5A
- a MOSFET-based feed-forward power supply, with output voltage adjustable from 15V to 18V by means of a potentiometer and rated current 0.5A

Both power supplies are provided with a current limiting circuit and with a shut-down device to switch off the voltage from the load without deactivating the power supplies control circuits. This board also includes resistive loads of different values for the detection of the output characteristics.

The board is supplied complete with a set of stackable, plug-in cables of suitable lengths and colours and with a training manual.

Power supply: 24Vac,1A,50/60Hz.



Thyristors, Triacs and their Applications

DL 2316

This system has been designed in 3 boards to allow both the theoretical and the practical study of thyristors and triacs for what concerns the control techniques and their typical applications within the control systems.

Power and Control Board

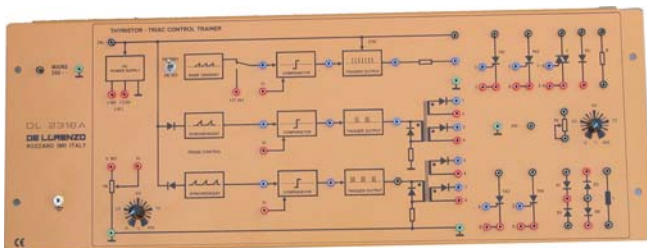

DL 2316A

It allows the autonomous study of the thyristors in the main single-phase bridge circuit configuration (semi- and totally-controlled) and in the ac/ac converters as well as the study of the triac in the control of the alternating voltage and in the controlled rectification. The power section includes: 4 thyristors, 1 triac, 4 diodes, 1 flywheel diode and 1 ohmic-inductive load.

The control section allows the realization of: proportional control, on-off control or phase control, both on the positive and negative semiwave. Furthermore, there is a potentiometer for the manual control of the devices activation. The board is supplied complete with a set of stackable, plug-in cables of suitable lengths and colours and with a training manual.

Power supply: 24Vac,1A,50/60Hz

Experiments

- SCR control with alternating voltage synchronous and in phase with the anode voltage
- SCR control with alternating voltage synchronous and in phase with the anode voltage supplying the gate with and without flywheel diode
- Half-wave rectifiers with ohmic-inductive load with and without flywheel diode
- Half controlled single-phase rectifier bridge (B2HZ)
- Half controlled single-phase rectifier bridge with (B2HKF) and without (B2HK) flywheel diode
- Fully controlled single phase rectifier bridge
- Control of full-wave rectification with ohmic load and with ohmic-inductive load
- Half-wave ac/ac converter
- Full-wave ac/ac converter
- Triac control in quadrant I
- Triac control in quadrant III
- Mains alternating voltage regulation
- Pulse train control
- Triac controlled rectifier



Light and Temperature Control

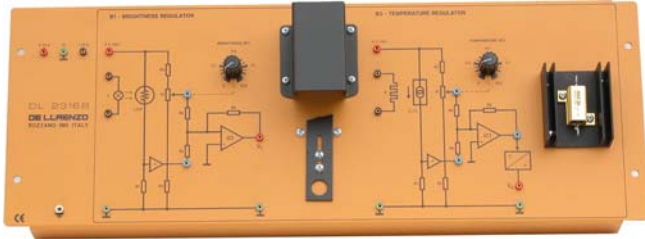

DL 2316B

This board contains two independent systems, for the control of the light and of the temperature respectively, each one complete with reference block, error amplifier, transducer and actuator. Together with the DL 2316A board, that contains the power circuits complete with relevant piloting, it is possible to realize an open and closed loop control both of the lighting system (24V, 15W lamp and photoresistor) and of the heating system (47 Ω , 25W heating element and integrated circuit sensor). The board is supplied complete with a set of stackable, plug-in cables of suitable lengths and colours and with a training manual.

Power supply: $\pm 15V_{dc}$, 100mA

Experiments

- DC operated lamp
- AC operated lamp
- Full-wave triac control
- Proportional control

Speed and Position Control

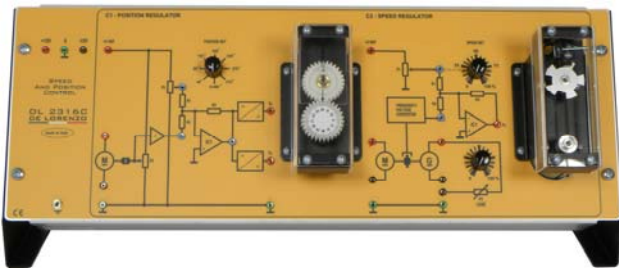

DL 2316C

This board contains two independent systems, for the control of the position and of the speed respectively, each one complete with reference block, error amplifier, transducer and actuator.

Together with the DL 2316A board, that contains the power circuits complete with relevant piloting, it is possible to realize an open and closed loop control both of the position system (geared motor coupled to a potentiometer) and of the speed system (variable load generator dc motor with optical transducer associated to an F/V converter).

The board is supplied complete with a set of stackable, plug-in cables of suitable lengths and colours and with a training manual.

Power supply: $\pm 15V_{dc}$, 100mA

Experiments

- Thyristor bidirectional converter
- Open-loop operation
- Closed-loop operation half-controlled bridge
- Closed-loop operation fully-controlled bridge



Temperature Control

DL 2155RGT

This system has been designed for the study of a model of a temperature industrial control; it is composed of two boards.

Temperature Basic Control

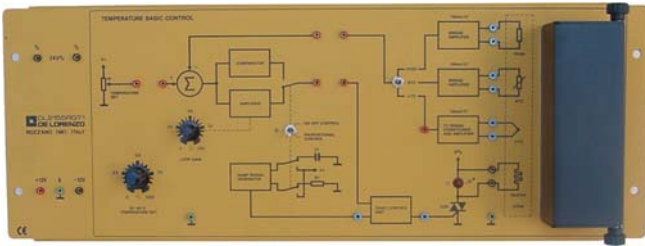

DL 2155RGT1

This board includes a small oven with a heating element and three temperature sensors (thermocouple, thermistor, and thermo-resistance) with relevant interface circuits.

Complete with error amplifier that can be configured for on-off or proportional control, and with a piloting circuit of the power stage with triac.

The board is supplied complete with a set of stackable, plug-in cables of suitable lengths and colours and with a training manual.

Power supply:

24Vac, 1A, 50/60Hz and $\pm 15Vdc$, 100mA

Experiments

- $V = f(t^\circ)$ characteristics of a thermocouple, with relevant linearization, of the thermistor and of the thermo-resistance
- Analysis of the operation of an on-off control
- Analysis of the operation of a proportional control

Advanced Temperature Control – PID Controller

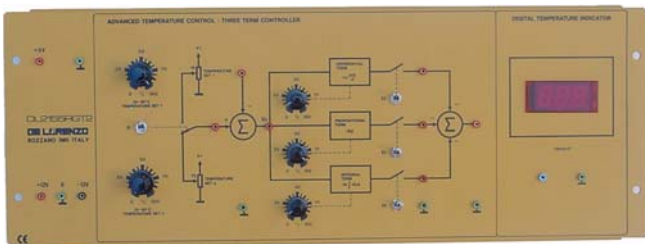

DL 2155RGT2

This board includes two reference signal generators, a comparison node and the three terms network (proportional, integral and derivative).

Complete with digital temperature indicator 100mV/°C.

This board is an option to the board DL 2155RGT1 since it uses its oven, the heating element and the temperature transducers.

The board is supplied complete with a set of stackable, plug-in cables of suitable lengths and colours and with a training manual.

Power supply: $\pm 15Vdc$, 100mA and +5Vdc, 150mA

Experiments

- Analysis of the operation of a proportional, proportional-derivative and proportional-integral control
- PID control circuits
- PID controllers calibration



Speed Control of a DC Motor

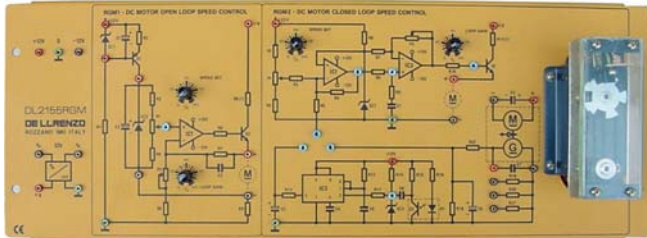

DL 2155RGM

This board has been designed to highlight the speed control techniques of a direct current motor.

The board is basically divided in two sections: the first one allows the study of the open loop speed control, while the second section deals with an actual closed loop speed control of the system.

The group under test, composed of a motor, a dynamometer and a speed optical transducer, is placed on the board.

The board is supplied complete with a set of stackable, plug-in cables of suitable lengths and colours and with a training manual.

Power supply: 12Vac, 2A, 50/60Hz and 15Vdc, 300mA

Experiments

- Study of open loop and closed loop speed control systems
- Analysis of the static and dynamic operation of an open loop controller
- Analysis of the static and dynamic operation of a closed loop controller
- Measurement of the speed through an optical transducer connected to a F/V converter or through a tachogenerator

Step Motor Control

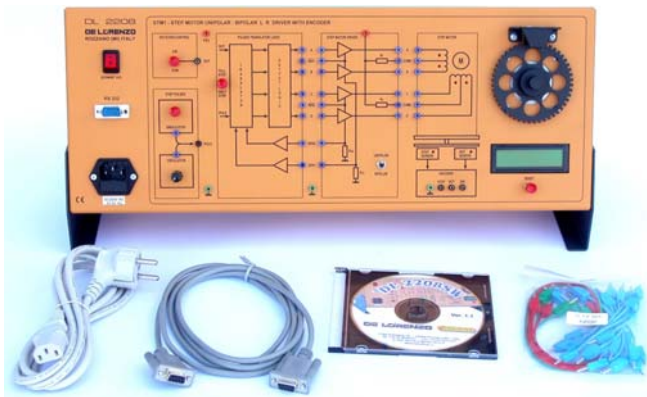

DL 2208

This board is designed to provide a valid support for the study of the operation and of the application criteria of these important electromechanical components.

It allows the students performing study and experimentation concerning the driving of a step motor, unipolar or bipolar.

The rotation can be performed with increments of a single step or with continuity, at a variable speed.

Position and direction are indicated by a disk.

An LCD display allows showing the number of steps, the number of turns, the rpm, the rotation direction and the selected parameters of the controller.

Technical Features

- Step angle: 1.8°
- Number of phases: 4
- Max. power: 16 W
- Sense of rotation: reversible
- Current/phase max: 1.5 A
- Variable frequency from 20 Hz to 500 Hz through potentiometer

Power supply: 90/260 Vac, 50/60 Hz

Experiments

- Analysis of the operation of a step motor
- Analysis of the control criteria and of the power modules
- Full step or half step
- Variable speed rotation control
- Inversion of the rotation direction
- Study of an incremental position encoder



Process Simulator with PID Control

DL 2330

This system has been designed with the objective of providing the student with a simple, although effective tool for the simulation and the control of physical systems through the identification of the mathematical model, the definition of the parameters and the calibration of the control network.
The system is composed of two boards.

Process Simulator

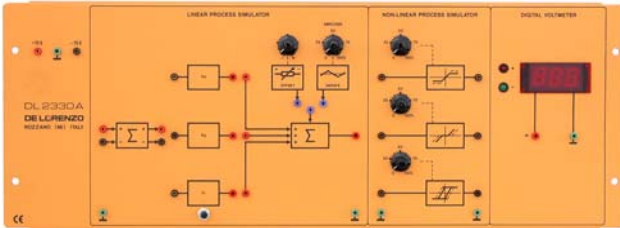

DL 2330A

This board is basically structured in two sections:

- a linear process simulation, with two summing amplifiers, three blocks with proportional, integral, derivative transfer functions, offset and drift generators
- a hysteresis non-linear simulation, dead band and threshold

It includes a digital voltmeter.

The board is supplied complete with a set of stackable, plug-in cables of suitable lengths and colours and with a training manual.

Power supply: $\pm 15\text{Vdc}$, 300mA

Experiments

- Analysis and simulation of linear processes
- Open and closed loop control of linear systems
- Behaviour of the control system against fixed or time variable disturbances
- Steady state error
- System with two time constants
- Calibration of a control system and criteria for the optimum setting of the PID parameters
- Transfer function of the PID controllers
- Method of permanent oscillation
- Method of damped oscillations
- Experimental study of the PI controller
- Experimental study of the PD controller
- Experimental study of the PID controller
- Analysis and study of typical non linear elements (saturation, threshold, hysteresis)

PID Controller

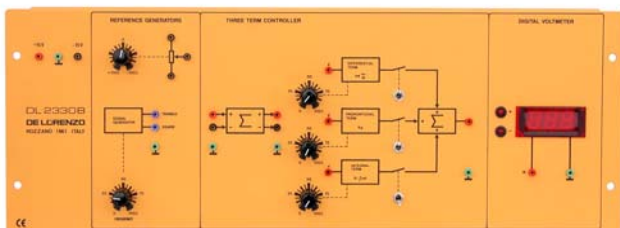

DL 2330B

This board is basically structured in two sections:

- variable frequency square and triangular wave reference signal generation
- three terms regulator with variable parameters and two summing amplifiers

It includes a digital voltmeter.

The board is supplied complete with a set of stackable, plug-in cables of suitable lengths and colours and with a training manual.

Power supply: $\pm 15\text{Vdc}$, 300mA



Power Electronics Board

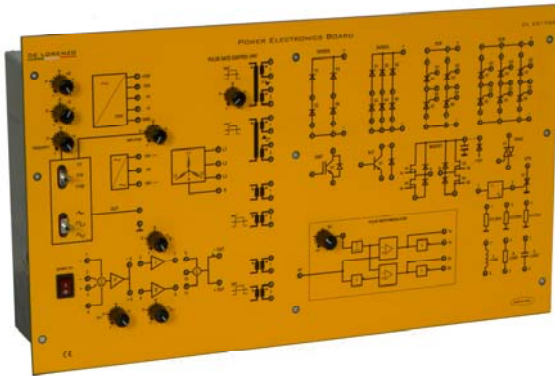

DL 2317SR

This board allows the study of several power electronics circuits, as detailed here under.

Technical Features

The following components are available on the board:

- Diodes for circuit M1U, M2U, M3U, M6U
- SCR for circuit M1C, M2C, M3C, M6C
- H bridge with MOSFET
- Pulse generator for SCR control
- Generator for H bridge control (PWM)
- Function Generator
- Three-phase generator (12 Vpp)
- Single-phase source (12 Vpp)

Built-in power supply.

Experiments - DL 2317SR

- Single-phase uncontrolled rectifier M1U and B2U
- Single-phase controlled rectifier M1C and B2C
- Three-phase, single wave, uncontrolled rectifier B3U
- Three-phase, single wave, controlled rectifier B3C
- Three-phase, full wave, uncontrolled rectifier B6U
- Three-phase, full wave, controlled rectifier B6C
- Pulse Width Modulation (PWM) circuit to control direct current
- PWM to control a motor with a H bridge
- PWM on H bridge to understand the principle of inverter

Experiments ON THE DC SUPPLY

- Basic pulse width modulation (PWM) circuits
- PWM with H-circuit, DC-evaluated
- PWM with H-circuit, sine-evaluated

Experiments WITH THE GTO (GATE-TURN-OFF)

- Firing pulse conditioning for the GTO
- The GTO as a DC actuator

Motor Board



DL 2318SR

Universal speed control system.

- With integrated four-quadrant display
- With variable centrifugal mass
- Dual-channel encoder
- Built-in four-quadrant amplifier

Technical features

- Linear H bridge to have full motor control
- Dual optical sensor for speed and direction
- Main Motor/Generator 12 V, 3000 rpm, 1.2 A, 3.2 Ncm
- Load to be connected to the secondary Motor/Generator
- Shunt to limit and measure the current



DIGITAL ELECTRONICS

Combinatory Logic

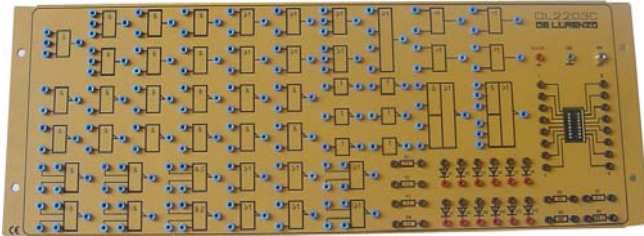

DL 2203C

This board allows the study of the following combinatory circuits:

adders, subtractors, multipliers, code converters, multiplexers and demultiplexers. The board is composed of:

- 4 AND (2-input)
- 3 AND (3-input)
- 12 NAND (2-input)
- 4 NAND (4-input)
- 2 NAND TRIGGER (4-input)
- 4 OR (2-input)
- 2 OR (3-input)
- 1 OR (4-input)
- 4 NOR (2-input)
- 2 NOR (4-input)
- 4 EX-OR (2-input)
- 6 inverters
- 2 AOI (2 and 3 input)
- 12 silicon diodes
- 8 resistances
- 1 dual-in-line 16-pin socket

Power supply: 5Vdc, 3W

Sequential Logic

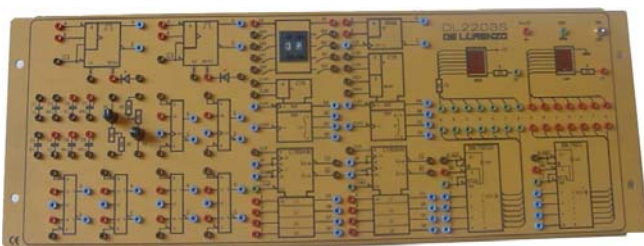

DL 2203S

This board allows the study of the following subjects:

MSI circuits in TTL logic, synchronous and asynchronous counters, shift registers, astable and monostable multivibrators, seven segment displays.

The board is composed of:

- 4 JK/MS flip-flop
- 2 D flip-flop
- a BCD synchronous counter
- a binary 4-bit synchronous counter
- a BCD asynchronous counter
- a binary 4-bit asynchronous counter
- 2 monostable multivibrators
- a shift register, 8-bit SI-SO
- 2 BCD 7-segment decoders
- 2 7-segment displays
- 2 BCD rotating switches
- 8 capacitors
- 2 linear potentiometers

Power supply: 5Vdc, 5W



HCT – ECL – CMOS

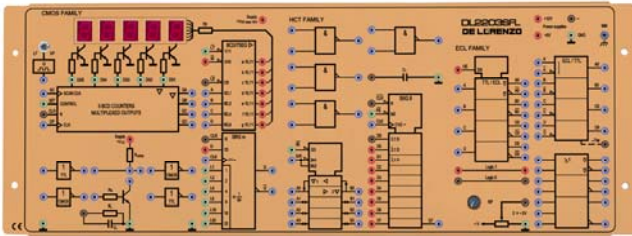

DL 2203SFL

This board allows the study of the following subjects:

- electrical characteristics of the integrated circuits of the various logic families: ECL, CMOS, HCT
- laws and principles for the assembling of interface circuits among the families
- logic gates
- multiplexed counters
- programmable shift registers
- bidirectional transmission gates
- level translators

The board is composed of three sections:

- the HCT section
- the ECL section
- the CMOS section

In each section various types of integrated circuits of the three different logic families are assembled.

Power supply: +5Vdc, +12Vdc, -5.2Vdc

Advanced Sequential Logic

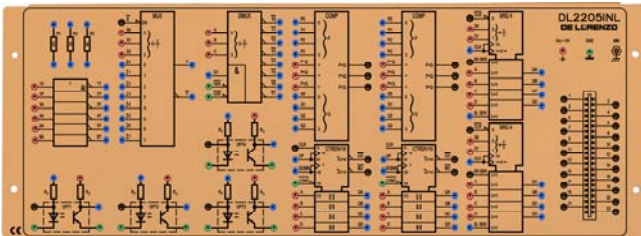

DL 2205INL

This board allows the study of the following circuits: counters, frequency dividers, cyclic programmable timers, data transfer between two shift registers.

Furthermore, the board includes interface circuits and a connector to allow for direct and easy interfacing to systems, devices and circuits prepared by the students.

The board is composed of:

- 4-bit comparators (2 off)
- 4-bit BCD counters (2 off)
- 4-bit shift registers (2 off)
- 8-to-1 line multiplexer
- 1-to-8 line demultiplexer
- NOT with open collector output (4 off)
- Optoisolators (4 off)
- a 22-pole connector, step 3.96 mm

Power supply: 5Vdc



Programmable Logic

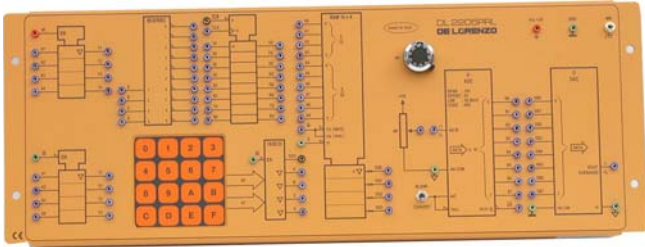

DL 2205PRL

This board allows the study of RAM memories and circuits using RAMs for storing logic information and for data transfer to a BUS.

The board is composed of:

- 4 + 4 buffers with three-state output
- 8-bit latch register (type D)
- 4-to-10 line decoder
- RAM 1024 x 4
- hexadecimal keypad
- coder for hexadecimal keypad
- 8-bit digital-to-analogue converter
- 8-bit analogue-to-digital converter
- multiturn potentiometer for generating voltages between 0 and 10V

Power supply: 5Vdc

Digital Board

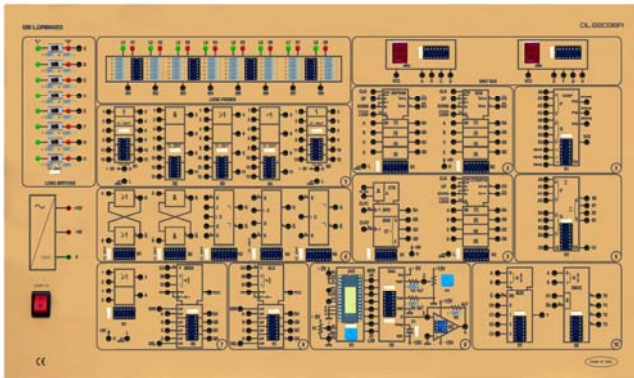

DL 2203SR

This board allows the study of several digital circuits.

Technical features:

- 4-bit comparator
- 4 JK-flip flops, can also be used as RS flip flops
- 4 D-flip flops
- 2 adders (4-bit), with input and output carry
- Multiplexer, 4 channels
- Demultiplexer, 4 channels
- Shift register (4-bit), parallel and serial operation possible, bi-directional
- ALU, for conducting 16 arithmetic and 16 logical computing operations with 4-bit dual numbers
- Binary counter (4-bit), up/down counter
- 2 inverters
- 2 Schmitt triggers, inverting
- Units complements for negating a 4-bit binary number
- Antivalence and equivalence gates
- EEPROM
- AD/DA converter 8-bit
- Auxiliary section on board:
 - 8 switches with led to generate logic level
 - 8 logic probes with led for high and low level
 - 2 seven segment led displays with BCD decoder

Built-in power supply

Experiments

- Basic logic circuits
- Schmitt triggers
- Bistable multivibrators
- Monostable multivibrators
- Code converters, coders
- Arithmetic circuits
- Counting circuits
- Register circuits
- Multiplex mode Arithmetic Logic Unit
- Memory circuits
- Analog-Digital converters
- Digital-Analog converters



TABLE OF INSTRUMENTATION

			NECESSARY INSTRUMENTATION			
CODE	BOARD		DIGITAL MULTIMETER	DUAL TRACE OSCILLOSCOPE	LF SIGNAL GENERATOR	FREQUENCY COUNTER
DISCRETE COMPONENTS LINEAR ELECTRONICS						
DL 2155AT	BJT voltage amplifiers		X	X	X	
DL 2155APT	BJT power amplifiers		X	X	X	
DL 2155ART	BJT feedback amplifiers		X	X	X	x 2
DL 2155FET	FET-MOSFET		x 2	X		
DL 2155RTD	Voltage regulators		x 2			
INTEGRATED COMPONENTS LINEAR ELECTRONICS						
DL 2155MVB	Transistor multivibrators		X	X	X	
DL 2155TRG	Schmitt trigger and NE		X	X	x	
DL 2155AOP	Operational amplifiers		X	X	X	
DL 2155FIL	Active filters			X	X	
DL 2155GEF	Function generators			X		
DL 2155DIS	Differentiators, integrators...		X	X	X	
DL 2155COM	Comparators		X	X	X	
DL 2155AMP	AC and DC amplifiers		X	X	X	
DL 2155SMA	Analogue switches, multiplexers			X	X	
DL 2155RTI	Voltage regulators		x 2			
APPLICATIONS						
DL 2155DAC	Digital-analogue converters		X	X		
DL 2155ADC	Analogue-digital converters		X	X		
DL 2155AC	Switching power supplies		X	X		
DL 2316	Thyristors, triacs, ...		X	X		
DL 2155RGT	Temperature control		X	X		
DL 2155RGM	DC motor speed control		X	X		
DL 2208	Step motor control		X	X		
DL 2330	Process simulator with PID		X	X	X	
DL 2317SR	Power electronics board		X	X		
DL 2318SR	Motor board		X			
DIGITAL ELECTRONICS						
DL 2203C	Combinatory logic			X		
DL 2203S	Sequential logic			X		
DL 2203SFL	HCT-ECL-CMOS			X		
DL 2205INL	Advanced sequential logic			X		
DL 2205PRL	Programmable logic			X		
DL 2203SR	Digital board		X			